

The Experts in Reliable RF Signal Management



End-to-End Solutions for RF Signal Routing

- ***Earth Stations and Teleports***
- ***Broadcast and CATV Headends***
- ***Government and Military***
- ***Command & Control Centers***
- ***Wireless Lab Test & Measurement Automation***

Quintech Electronics & Communications Customer List

Government



Domestic



International





About Quintech:

Quintech Electronics & Communications, Inc. (www.quintechelectronics.com) founded in 1989, is a state-of-the-art designer and manufacturer of RF signal management communications equipment. The company's products are globally distributed and vital for RF signal management. Quintech products are the keystones to the automation of today's advanced telecommunication network infrastructures and test laboratories. Our worldwide customers include satellite, government, wireless telecommunications, broadcast and CATV service providers. Quintech produces RF matrix switches, RF over fiber, redundancy switches, relay switches, splitters, combiners, amplifiers and DC powering products and equipment. The products are available in L-band, broadband, IF and wireless frequencies. These RF signal management products are used for monitor and control, test and measurement, redundancy applications and surveillance. Quintech products are designed for high reliability and maximized uptime providing years of maintenance free service. We emphasize the design and development of superior RF signal management products to provide the highest quality systems and solutions for our valued customers.

RF & L-Band Matrix Routers:

The company designs and manufactures the world's largest configuration matrix switches in the smallest form factor. These are state of the art products that simplify and facilitate RF signal management solutions. Quintech matrices span frequencies from DC to 6 GHz. These superior designs are used worldwide in gateways, teleports, broadcast and cable headends.

RF Test Matrices:

Our customers include wireless service providers, network equipment and component manufacturers. Our products are used for laboratory, R&D and product conformance, interoperability, network load, software regression and manufacturing testing applications which support legacy network compatibility with MIMO, LTE, LTE-U, WiFi, and other mobility testing. We also provide Lab Automation and Management software that facilitates wireless lab testing.

Quintech Electronics & Communications, Inc. sells its products worldwide in over 100 countries.

TABLE OF CONTENTS:

Broadcast Satellite Government

XTREME 256	256 Port RF Fan-Out Matrix Switch	Page 5
XTREME 256-C	256 Port RF Fan-In Matrix Switch	Page 6
XTREME 160	80 Port RF Fan-Out Matrix Switch	Page 7
XTREME 160-C	80 Port RF Fan-In Matrix Switch	Page 8
XTREME 80	80 Port RF Fan-Out Matrix Switch	Page 9
XTREME 80-C	80 Port RF Fan-In Matrix Switch	Page 10
XTREME 32	32 Port RF Fan-Out Dual Band + S-Band Matrix Switch	Page 11
XTREME 32-C	32 Port RF Fan-In L-Band + S-Band Matrix Switch	Page 12
XTREME 32 Hybrid	Dual 8x8 Hybrid RF Matrix Switch	Page 13
XTREME 32 Bi-Directional	32 Port Fan-Out Bi-Directional RF Matrix Switch	Page 14
RP1	Modular 1RU Chassis	Page 15
RFM	RF Routing Switch	Page 16
AMP 2150	L-Band Line Amplifier	Page 29
QS/QC	Signal Distribution	Page 22
LS/LC 2150 Series	Splitters and Combiners, Active and Passive, L-Band	Page 23-25

Wireless/ATE

NEXUS-4	6 GHz RF Matrix Switch for Wireless Technologies	Page 18
NEXUS Wi-5G	6 GHz RF Test Switch	Page 17
NEXUS-M	6 GHz Bi-Directional RF Mesh Attenuator Matrix	Page 19
NEXUS-R	High Power Blocking Bi-Directional RF Matrix	Page 20

Broadband & CATV

XTREME 32 Bi-Directional	32 Port Fan-Out Bi-Directional RF Matrix Switch	Page 12
RFM	Monitoring Switch	Page 16
QS/QC	Signal Distribution	Page 22
LS 1000A	Active Broadband Splitters	Page 23
LC 1000A	Active Broadband Combiners	Page 24
LSC 1000P	Passive Broadband Splitter/Combiner	Page 25

General Products

Evertz Products

Evertz Multiframe	7800FR, 7801FR Multiframe	Page 30
Evertz Rack-Based Modules	7807LT-2, 7807LR-2, 7708LT, 7708LR Rack Based Modules	Page 31-32
Evertz Integrated Receiver Decoders	DVBS/S/S2X MPEG-2/H.264 SD/ HD Receiver Decoder	Page 33-34
Evertz 2406/ 2408	Fiber Optic Receiver Transmitter	Page 35
Evertz 2400 ODU	Outdoor Integrated RF Fiber Transmission System	Page 36
Evertz 7780D4A-ASI	Quad ASI TDM-Demux	Page 37
Evertz 7780M4-ASI	Quad ASI TDM-Mux	Page 38

RF Splitters and Combiners

QS/QC	Signal Distribution	Page 22
LS 2150A	Splitters, Active, L-Band	Page 23
LS 2150P	Splitters, Passive, L-Band	Page 24
LC 2150A	Combiners, Active, L-Band	Page 25
LS 1000A	Splitters, Active, 5-1000MHz	Page 26
LC 1000A	Combiners, Active 5-1000MHz	Page 27
LSC 1000P	Splitter/ Combiner, Passive Broadband	Page 28

Software

Q-LAAMP	Lab Automation and Management Package	Page 21
----------------	---------------------------------------	---------

XTREME 256

256 Port Fan-Out L-Band RF Matrix Switch

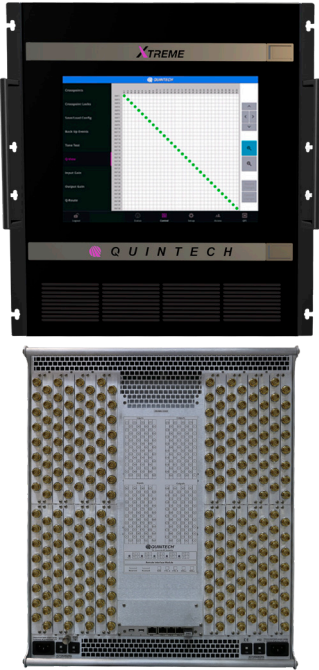

XTREME 256

General Description:

The **XTREME 256** next generation L-band matrix switch features 256 ports in a compact 12 RU chassis. The **XTREME 256** is a full fan-out (distributive), non-blocking switch where an input can be routed to any or all outputs. The **XTREME 256** features an industry exclusive flexible matrix architecture (patented) that supports both symmetric and asymmetric configurations of 256 combined inputs and outputs in a single chassis. Asymmetric configurations such as 64x192, 96x160, and more can be implemented as well as the standard 128x128 configuration. It is designed for maximum reliability with redundant and hot-swappable power supplies, fans trays, and control cards plus RF redundancy. It is also designed for ease of maintenance with built-in self-test (BIST) capability and the ability to hot-swap all active components from the front of the unit. The **XTREME 256** is highly scalable and can easily be expanded up to 2048x2048 using multiple **XTREME 256** modules. Optional integrated expansion ports allow for large systems without using external expansion modules, significantly reducing system size and number of cables.

Features & Benefits:

- Compact modular design, 256 ports in 12 RU, easily expandable to 2048x2048
- Asymmetrical configurations up to 248 outputs in a single chassis
- Adjustable gain on inputs and outputs to allow RF performance optimization
- Option for fiber optic inputs
- Easy hot-swap of all active cards, power supplies, and fan trays from the front
- Redundant hot-swap control cards plus independent GUI control system
- Remotely controlled via web browser GUI interface, SNMP, TELNET or TCP/IP via customer supplied PC

Specifications:*1	XTREME 256
Configuration:	128 Inputs/128 Outputs
RF Connectors:	F-Type, BNC 75 Ω or 50 Ω, SMA, Mixed or Optical Input Receivers SC/APC or LC/APC
Impedance:	75 Ω or 50 Ω
Operating Frequency:	850-2450 MHz
Frequency Response:	± 1 dB Typ. ± 2 dB Max. ± .2 dB Typ. ± .5 dB Max. Over Any 40 MHz Channel
Input P1dB:	0 dBm
Noise Figure:	<20 dB @ 0 dB Input Gain
OIP3:	+10 dBm Min.
Input Return Loss:	14 dB Typ. 12 dB Min.
Output Return Loss:	16 dB Typ. 12 dB Min.
Isolation (input-to-input):	75 dB Typ. 65 dB Min.
Isolation (output-to-output):	75 dB Typ. 65 dB Min.
Isolation (input-to-output):	65 dB Typ. 55 dB Min.
Input Gain Range:	-17 dB to +13.5 dB in 0.5 dB Steps
Output Gain Range:	-14.5 dB to +33 dB in 0.5 dB Steps
RF Sensing:	-5 dBm to -50 dBm
Group Delay:	5 ns Max.
Switching Time:	125 ms
Local Control:	15" Front Panel Touchscreen
Remote Control:	SNMP, TELNET, TCP/IP; Web Browser Interface Via Ethernet
Power Requirements:	100-250 VAC Autoranging, 50/60 Hz
Power Consumption:	525 W @ 120 VAC 650 W @ 240 VAC
Size:	12 RU Total Rack Space Required, 21" H x 19" W x 20.5" D to Rear Panel (22" Including Rear Handles)
Weight:	150 lbs

*Specifications may vary with connector type. See individual specification sheet for specific performance data.

*Specifications valid at unity gain (Input gain = 0 dB , Output gain = 0 dB)

XTREME 256-C

256 Port Fan-In L-Band RF Matrix Switch

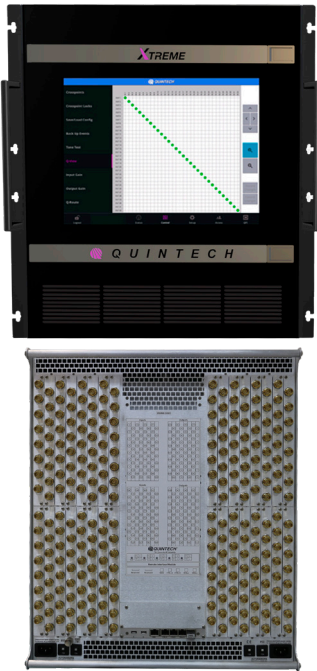

XTREME 256-C

General Description:

The **XTREME 256-C** next generation L-band matrix switch features 256 ports in a compact 12 RU chassis. The **XTREME 256-C** is a full fan-in (combining), non-blocking switch where one or multiple inputs can be routed to an output. The **XTREME 256-C** features an industry exclusive flexible matrix architecture (patented) that supports both symmetric and asymmetric configurations of 256 combined inputs and outputs in a single chassis. Asymmetric configurations such as 192x64, 160x96, and more can be implemented as well as the standard 128x128 configuration. It is designed for maximum reliability with redundant power, fans trays, and control cards plus RF redundancy. It is also designed for ease of maintenance with built-in self-test (BIST) capability and the ability to hot-swap all active components from the front of the unit. The **XTREME 256-C** is highly scalable and can easily be expanded up to 2048x2048 using multiple **XTREME 256-C** modules. Optional integrated expansion ports allow for large systems without using external expansion modules, significantly reducing system size and number of cables.

Features & Benefits:

- Compact modular design, 256 ports in 12 RU, easily expandable to 2048x2048
- Asymmetrical configurations up to 248 inputs in a single chassis
- Adjustable gain on inputs allow RF performance optimization
- Option for fiber optic inputs
- Touchscreen local control and embedded web GUI interface
- Easy hot-swap of all active cards, power supplies, and fan trays from the front
- Redundant hot-swap control cards plus independent GUI control system
- Remotely controlled via web browser GUI interface, SNMP, TELNET or TCP/IP via customer supplied PC

Specifications: ^{*1}	XTREME 256-C
Configuration:	128 Inputs/128 Outputs
RF Connectors:	F-Type, BNC 75 Ω or 50 Ω, SMA, Mixed or Optical Input Receivers SC/APC or LC/APC
Impedance:	75 Ω or 50 Ω
Operating Frequency:	850-2450 MHz
Frequency Response:	± 3 dB ± .75 dB Over Any 36 MHz Channel
Input P1dB:	+6 dBm
Noise Figure:	<23 dB @ 0 dB Gain
OIP3:	+15 dBm
Input Return Loss:	14 dB Typ. 12 dB Min.
Output Return Loss:	15 dB Typ. 12 dB Min.
Isolation (input-to-input):	75 dB Typ. 65 dB Min.
Isolation (output-to-output):	75 dB Typ. 65 dB Min.
Isolation (input-to-output):	60 dB Typ. 55 dB Min.
Input Gain Range:	-17.5 dB to +14 dB in 0.5 dB Steps
RF Sensing:	+10 dBm to -50 dBm
Output P1dB:	+14 dBm
Local Control:	15" Front Panel Touchscreen
Remote Control:	SNMP, TELNET, TCP/IP; Web Browser Interface Via Ethernet
Inter-Module Control Data:	XR Bus
Power Requirements:	100-250 VAC Autoranging, 50/60 Hz
Power Consumption:	525 W @ 120 VAC 650 W @ 240 VAC
Size:	12 RU Total Rack Space Required, 21" H x 19" W x 20.5" D to Rear Panel 22" (Including Rear Handles)
Weight:	150 lbs

^{*1}Specifications may vary with connector type. See individual specification sheet for specific performance data. ¹Specifications valid at unity gain (Input gain = 0 dB , Output gain = 0 dB)

XTREME 160

160 Port Fan-Out L-Band RF Matrix Switch



General Description:

The **XTREME 160** next generation L-band matrix switch features up to 160 ports in a compact 4 RU chassis. The **XTREME 160** is a full fan-out (distributive), non-blocking switch where an input can be routed to any or all outputs. The **XTREME 160** features an industry exclusive flexible matrix architecture (patented) that supports both symmetric and asymmetric configurations of 160 combined inputs and outputs in a single chassis. Asymmetric configurations such as 32x128, 48x80, and more can be implemented as well as the standard 64x64 configuration. Optional 13/18V, 22 kHz tone LNB power is available on all input ports. The **XTREME 160** is designed for maximum reliability with redundant power and control cards.

XTREME 160

Features & Benefits:

- 50-200 MHz and 850-2450 MHz
- Compact modular design up to 160 ports in 4 RU chassis
- Asymmetrical configurations up to (48x80, 32x128, 64x96) in a single chassis
- LNB power 750 MA per input 13/18 V with 22 KHz tone
- Fiber optic receivers
- Adjustable gain and attenuation on all inputs and outputs allows the user to adjust the RF level for optimum performance
- Fast and easy hot-swap (less than 30 seconds) of any active cards

Specifications: ^{*1}	XTREME 160
Configurations:	64x64, 48x80, 80x48, 32x128, 128x32
RF Connectors:	F-Type, BNC 75 Ω or 50 Ω, SMA, Mixed or Optical Input Receivers SC/APC or LC/APC
Impedance:	75 Ω or 50 Ω
Operating Frequency:	50-200 MHz & 850-2450 MHz
Frequency Response:	+/-1.5 dB (950-2150 MHz), +/-2.0 dB (850-2450 MHz) +/-0.5 dB Over Any 36 MHz Channel
Input P1dB:	0 dBm
Noise Figure:	14 dB
OIP3:	+10 dBm
Input Return Loss:	14 dB
Output Return Loss:	14 dB
Isolation (input-to-input):	60 dB
Isolation (output-to-output):	60 dB
Isolation (input-to-output):	55 dB (950-2150 MHz), 50 dB (850-2450 MHz)
Input Gain Range:	-23.5 to +8 dB in .5 dB Steps
Output Gain Range:	-23.5 to +8 dB in .5 dB Steps
LNB Power Each Port:	0/13/18 V, 22 kHz Tone Individual ports limited to 750 mA 700 W Total System Power Available to LNB
Optical Wavelength:	900-1650 nm
Optical Return Loss:	14 dB
Optical Connectors:	SC/APC, LC/APC
Local Control:	8.4" Touchscreen Display
Remote Control:	SNMP, TELNET, TCP/IP, Web Browser Interface Via Ethernet
Power Requirements:	100-240 VAC Autoranging, 50/60 Hz
Power Consumption:	165 W Typical
Size:	4 RU: 7"H x 19"W x 23.25 D"

¹Specifications valid at unity gain (Input gain = 0 dB , Output gain = 0 dB)

*Specifications may vary with connector type and size configuration. See individual specification sheet for specific performance data.

XTREME 160-C

160 Port Fan-In L-Band RF Matrix Switch



XTREME 160-C

General Description:

The **XTREME 160-C** next generation L-band matrix switch features up to 160 ports in a compact 4 RU chassis. The **XTREME 160-C** is a full fan-in (combining), non-blocking switch where one or multiple inputs can be routed to an output. The **XTREME 160-C** features an industry exclusive flexible matrix architecture (patented) that supports both symmetric and asymmetric configurations of 160 combined inputs and outputs in a single chassis. Asymmetric configurations such as 128x32 can be implemented as well as the standard 64x64 configuration. The **XTREME 160-C** is designed for maximum reliability with redundant power supplies and control cards.

Features & Benefits:

- Compact modular design with a variety of configurations adding to 160 ports in 4 RU
- Easy hot-swap of all RF cards, power supplies and control cards
- Option for fiber optic inputs
- Independent input and output gain control
- Remotely controlled via web browser GUI interface, SNMP, Telnet or TCP/IP via customer supplied PC
- Redundant hot-swap control cards

Specifications: *1	XTREME 160-C
Configurations:	64x64, 80x48, 128x32
RF Connectors:	F-Type, BNC 75 Ω or 50 Ω, SMA, Mixed or Optical Input Receivers SC/APC or LC/APC
Impedance:	75 Ω or 50 Ω
Operating Frequency:	850-2450 MHz
Frequency Response:	+/-1.5 dB (950-2150 MHz), +/-2.0 dB (850-2450 MHz) +/-0.5 dB Over Any 36 MHz Channel
Input P1dB:	0 dBm
Noise Figure:	14 dB @ 0 dB Gain
OIP3:	+10 dBm
Input Return Loss:	14 dB
Output Return Loss:	14 dB
Isolation (input-to-input):	60 dB
Isolation (output-to-output):	60 dB
Isolation (input-to-output):	55 dB (950-2150 MHz), 50 dB (850-2450 MHz)
Input Gain Range:	-23.5 to +8 dB in .5 dB Steps
Output Gain Range:	-23.5 to +8 dB in .5 dB Steps
Local Control:	8.4" Touchscreen Display
Remote Control:	SNMP, TELNET, TCP/IP, Web Browser Interface Via Ethernet
Power Requirements:	100-240 VAC Autoranging, 50/60 Hz
Power Consumption:	160 W
Size:	4 RU: 7"H x 19"W x 23.25 D"

*Specifications may vary with connector type. See individual specification sheet for specific performance data.

*Specifications may vary with connector type and size configuration. See individual specification sheet for specific performance data.

XTREME 80

80 Port Fan-Out L-Band RF Matrix Switch



XTREME 80

General Description:

The **XTREME 80** next generation L-band matrix switch features 80 ports in a compact 2 RU chassis. The **XTREME 80** is a full fan-out (distributive), non-blocking switch where an input can be routed to any or all outputs. The **XTREME 80** features an industry exclusive flexible matrix architecture (patented) that supports both symmetric and asymmetric configurations of 80 combined inputs and outputs in a single chassis. Asymmetric configurations such as 16x64, 24x40, and more can be implemented as well as the standard 32x32 configuration. Optional 13/18V, 22 kHz tone LNB power is available on all input ports. The **XTREME 80** is designed for maximum reliability with redundant power and control cards.

Features & Benefits:

- 50-200 MHz and 850-2450 MHz or 50-1000 MHz frequency range
- Compact modular design up to 80 ports in 2 RU chassis
- Asymmetrical configurations up to (32x32, 16x64, 24x40) in a single chassis
- LNB power 750 mA per input 13/18 V with 22 KHz tone
- Option for fiber optic inputs
- Fiber optic receivers
- Adjustable gain and attenuation on all inputs and outputs allows the user to adjust the RF level for optimum performance
- Fast and easy hot-swap (less than 30 seconds) of any active cards

Specifications: ^{*1}	XTREME 80
Configurations:	16x64, 24x40, 32x32, 40x24, 64x16, 32x48, 20x48, 60x20, 48x32
RF Connectors:	F-Type, BNC 75 Ω or 50 Ω, SMA, Mixed or Optical Input Receivers SC/APC or LC/APC
Impedance:	75 Ω or 50 Ω
Operating Frequency:	50-200 MHz & 850-2450 MHz or 50-1000 MHz
Frequency Response:	+/-1.5 dB +/-0.5 dB Over Any 36 MHz Channel
Input P1dB:	0 dBm
Noise Figure:	13 dB @ 0 dB Gain
OIP3:	+10 dBm
Input Return Loss:	14 dB
Output Return Loss:	14 dB
Isolation (input-to-input):	60 dB
Isolation (output-to-output):	60 dB
Isolation (input-to-output):	55 dB
Input Gain Range:	-19.5 dB to +12 dB (32x32); -24 to +8 dB for (16x64)
Output Gain Range:	-15.5 dB to +16 dB, All Builds
LNB Power Each Port:	0/13/18 V, 22 kHz Tone Individual ports limited to 750 mA 500 W of Total System Power Available to LNB
Optical Wavelength:	900-1650 nm
Optical Return Loss:	14 dB
Optical Connectors:	SC/APC, LC/APC
Local Control:	Front Panel 2.2" Display and Rotary Switch Joystick
Remote Control:	SNMP, TELNET, TCP/IP, Web Browser Interface Via Ethernet
Power Requirements:	100-240 VAC Autoranging, 50/60 Hz
Power Consumption:	165 W Typical, 345 W with LNB Option (32x32), 255 W with LNB Option (16x64)
Size:	2 RU: 3.5"H x 19"W x 23.25 D"

¹Specifications valid at unity gain (Input gain = 0 dB , Output gain = 0 dB)

*Specifications may vary with connector type. See individual specification sheet for specific performance data.

XTREME 80-C

80 Port Fan-In L-Band RF Matrix Switch



XTREME 80-C

General Description:

The **XTREME 80-C** next generation L-band matrix switch features 80 ports in a compact 2 RU chassis. The **XTREME 80-C** is a full fan-in (combining), non-blocking switch where one or multiple inputs can be routed to an output. The **XTREME 80-C** features an industry exclusive flexible matrix architecture (patented) that supports both symmetric and asymmetric configurations of 80 combined inputs and outputs in a single chassis. Asymmetric configurations such as 64x16 can be implemented as well as the standard 32x32 configuration. The **XTREME 80-C** is designed for maximum reliability with redundant power supplies and control cards.

Features & Benefits:

- Compact modular design with a variety of configurations adding to 80 ports in 2 RU
- Easy hot-swap of all RF cards, power supplies and control cards
- Option for fiber optic inputs
- Independent input and output gain control
- Remotely controlled via web browser GUI interface, SNMP, Telnet or TCP/IP via customer supplied PC
- Redundant hot-swap control cards

Specifications: *1	XTREME 80-C
Configurations:	32x32, 64x16
RF Connectors:	F-Type, BNC 75 Ω or 50 Ω, SMA, Mixed or Optical Input Receivers SC/APC or LC/APC
Impedance:	75 Ω or 50 Ω
Operating Frequency:	850-2450 MHz
Frequency Response:	+/-1.5 dB +/-0.5 dB Over Any 36 MHz Channel
Input P1dB:	0 dBm
Noise Figure:	13 dB @ 0 dB Gain
OIP3:	+10 dBm
Input Return Loss:	14 dB
Output Return Loss:	14 dB
Isolation (input-to-input):	60 dB
Isolation (output-to-output):	60 dB
Isolation (input-to-output):	55 dB
Input Gain Range:	-14.5 to +17 dB
Output Gain Range:	-19.5 to +12 dB (32X32)
Local Control:	Front Panel 2.2" LCD Display with Rotary Switch Joystick
Remote Control:	SNMP, TELNET, TCP/IP, Web Browser Interface Via Ethernet
Power Requirements:	100-240 VAC Autoranging, 50/60 Hz
Power Consumption:	160 W
Size:	2 RU: 3.5"H x 19"W x 23.25 D"

*Specifications may vary with connector type. See individual specification sheet for specific performance data.

1Specifications valid at unity gain (Input gain = 0 dB , Output gain = 0 dB)

XTREME 32

32 Port Fan-Out Dual Band + S-Band RF Matrix Switch



XTREME 32

General Description:

The **XTREME 32** Dual Band matrix switch is a full fan-out (distributive) non-blocking signal management solution that routes an input to any or all outputs. The design features an industry exclusive architecture that supports both symmetric and asymmetric configurations of 32 combined inputs and outputs in a compact 1 RU chassis. Hot-swappable redundant power supplies, I/O Modules, and a field replaceable cooling fan provide maximum reliability.

Features & Benefits:

- 50-200 MHz, 850-2500 MHz & 950-3500 MHz operating range
- Flexible matrix configurations (16x16, 4x28, 8x24)
- LNB power 750 mA per Input 13/18 V with 22 kHz tone
- Option for fiber optic inputs
- Adjustable input and output gain
- Redundant hot-swappable power supplies
- Hot-swappable input and output adapters
- Dual gigabit ethernet ports
- Field replaceable cooling fan

Specifications: ^{*1}	L-Band			S-Band
Configurations:	4x28, 8x24, 12x20, 16x16, 20x12, 24x8, 28x4			16x16
RF Connectors:	F-Type, BNC 75 Ω or 50 Ω, SMA, Mixed or Optical Input Receivers SC/APC or LC/APC			SMA
Impedance:	75 Ω or 50 Ω			50 Ω
Operating Frequency:	50-200 MHz	950-2150 MHz	850-2500 MHz	950-3500 MHz
Frequency Response:	+/- 2.5 dB	+/- 1.5 dB	+/- 2.5 dB	+/- 2.0 dB
Any 36 MHz:	+/- 0.8 dB	+/- 0.5 dB	+/- 0.7 dB	+/- 0.5 dB Max.
Input P1dB:	0 dBm			
Noise Figure:				
Default Gain:	20 dBm Max.	13 dBm Max.	14 dBm Max.	14 dB max
Max Input Gain:				10 dB Typical*
OIP3:	9 dBm Min.	10 dBm Min.	9 dBm Min.	8 dBm Min.
Input Return Loss:	12 dBm Min.	14 dBm Min.	12 dBm Min.	14 dB
Output Return Loss:	12 dBm Min.	14 dBm Min.	12 dBm Min.	14 dB
Isolation (input-to-input):	60 dB			
Isolation (output-to-output):	60 dB			
Isolation (input-to-output):	55 dB			45 dB
Input Gain Range:	-19.5 to 12 dB in 0.5 dB Steps			
Output Gain Range:	-15.5 to 16 dB in 0.5 dB Steps			-20.5 to 11 dB in .5 dB steps
LNB Power Each Port:	0/13/18 V, 22 kHz			
	250 W available, Individual ports limited to 750 mA			
	Short Circuit Protection with Automatic Reset			
	Status: Under Current (<50mA), Short and Normal			
Optical Wavelength:	900-1650 nm			
Optical Return Loss:	14 dB			
Optical Connectors:	SC/APC, LC/APC			
Remote Control:	SNMP, TELNET, TCP/IP, Web Browser Interface Via Ethernet			
Power Requirements:	100-240 VAC Autoranging, 50/60 Hz 5A Max.			
Power Consumption:	100W Typical, 200 W Max. with LNB Optional			
Local Control:	Front Panel 2.2" LCD Display with Rotary Switch Joystick			
Size:	1 RU: 1.75"H x 19"W x 18.5 D"			

*Specifications may vary with connector type. See individual specification sheet for specific performance data.

¹Specifications valid at unity gain (Input gain = 0 dB, Output gain = 0 dB)

XTREME 32-C

32 Port Fan-In L-Band + S-Band RF Matrix Switch



XTREME 32-C

General Description:

The **XTREME 32-C** next generation L-band matrix switch features 32 ports in a compact 1 RU chassis. The **XTREME 32-C** is a full fan-in (combining), non-blocking switch where one or more inputs can be routed to any output. The **XTREME 32-C** features an industry exclusive flexible matrix architecture that supports both symmetric and asymmetric configurations of 32 combined inputs and outputs in a single chassis. Asymmetric configurations such as 28x4, 24x8, and more can be implemented as well as the standard 16x16 configuration. The **XTREME 32-C** is designed for maximum reliability with redundant and hot-swappable power supplies.

Features & Benefits:

- 50-200 MHz, 850-2500 MHz & 950-3500 MHz operating range
- Compact design with a variety of configurations adding to 32 ports in 1 RU
- Easy hot-swap power supplies, fan and adapters
- Independent input and output gain control
- Option for fiber optic inputs
- Remotely controlled via web browser GUI interface, SNMP, Telnet or TCP/IP via customer supplied PC
- Hot-swappable input and output adapters
- Flexible matrix configurations (16x16)
- Redundant hot swappable power supplies
- Dual gigabit ethernet ports
- Field replaceable cooling fan

Specifications: ^{*1}	L-Band		S-Band
Configurations:	4x28, 8x24, 12x20, 16x16, 20x12, 24x8, 28x4		16x16
RF Connectors:	F-Type, BNC 75 Ω or 50 Ω, SMA, Mixed or Optical Input Receivers SC/APC or LC/APC		SMA
Impedance:	75 Ω or 50 Ω		50 Ω
Operating Frequency:	850-2500 MHz	50-200 MHz & 950-2150 MHz	950-3500 MHz
Frequency Response:	+/- 2.0 dB +/- 0.5 dB Max. (Over any 36 MHz Channel)		+/- 3.0 dB +/- 0.7 dB Max. (Over any 36 MHz Channel)
Input P1dB:	0 dBm		
Noise Figure:	13 dB @ 0 dB Gain (One Connection)	13 dB Max. (22 dB Full Fan-In)	15 dB Max. (24 dB Full Fan-In)
Default Gain:	13 dB @ 0 dB Gain (One Connection)	13 dB Max. (22 dB Full Fan-In)	15 dB Max. (24 dB Full Fan-In)
Max Input Gain:		9 dB Typical* (21 dB Full Fan-In)	10 dB Typical* (23 dB Full Fan-In)
OIP3:	10 dBm Min.	10 dBm Min.	8 dBm Min.
Input Return Loss:	14 dB		
Output Return Loss:	14 dB		
Isolation (input-to-input):	60 dB	50 dB	45 dB
Isolation (output-to-output):	60 dB	50 dB	45 dB
Isolation (input-to-output):	55 dB	50 dB	45 dB
Input Gain Range:	-14.5 to 17 dB in 0.5 dB Steps	-19.5 to 12 dB in .5 dB steps	-19.5 to 12 dB in .5 dB steps
Output Gain Range:	-18.5 to 13.0 dB in 0.5 dB Steps	-20.5 to 11 dB in .5 dB steps	-20.5 to 11 dB in .5 dB steps
Local Control:	Front Panel 2.2" LCD Display with Rotary Switch Joystick		
Remote Control:	SNMP, TELNET, TCP/IP, Web Browser Interface Via Ethernet		
Power Requirements:	100-240 VAC Autoranging, 50/60 Hz		
Power Consumption:	100W Typical		
Size:	1 RU: 1.75"H x 19"W x 18.5 D"		

¹Specifications valid at unity gain (Input gain = 0 dB , Output gain = 0 dB)

*Specifications may vary with connector type. See individual specification sheet for specific performance data.

XTREME 32

Dual 8x8 Hybrid RF Matrix Switch

General Description:

The **XTREME 32** Hybrid matrix switch is an L-band matrix switch that features a non-blocking 8x8 splitting matrix and a non-blocking 8x8 combining matrix with hot-swap I/O cards, redundant power supplies, and control module in a compact 1 RU chassis. Dual 10/100/1000 Ethernet ports allow for redundant control connections.



XTREME 32

Features & Benefits:

- 850-2500 MHz operating range
- Redundant hot-swappable power supplies
- Hot-swappable input and output adapters
- Adjustable input and output gain
- Dual gigabit ethernet ports
- Field replaceable cooling fan
- Fan-out LNB power option on input adapters
- Option for fiber optic inputs

Specifications:	Full Fan-out		Full Fan-in	
Configurations:	8x8		8x8	
RF Connectors:	F-Type, BNC 75 Ω or 50 Ω, SMA, Mixed or Optical Input Receivers SC/APC or LC/APC			
Impedance:	75 Ω or 50 Ω		75 Ω or 50 Ω	
Operating Frequency:	950-2150 MHz	850-2500 MHz	950-2150 MHz	850-2500 MHz
Frequency Response: Any 36 MHz:	+/- 1.5 dB	+/- 3 dB	+/- 1.5 dB	+/- 2.5 dB
	+/- .5 dB	+/- .7 dB	+/- .5 dB	+/- .5 dB
Input P1dB:	0 dBm Min.		0 dBm Min.	
Noise Figure:	13 dB Max.	14 dB Max.	13 dB Max.	21 dB Max.
OIP3:	10 dBm Min.	10 dBm Min.	10 dBm Min.	10 dBm Min.
Input Gain Range:	-15.5 to 16 dB in 0.5 dB steps		-17.5 to 14 dB in 0.5 dB steps	
Output Gain Range:	-14.5 to 17 dB in 0.5 dB steps		-13.5 to 18 dB in 0.5 dB steps	
Isolation (input-to-input):	60 dB Min.	60 dB Min.	60 dB Min.	60 dB Min.
Isolation (output-to-output):	60 dB Min.	60 dB Min.	60 dB Min.	60 dB Min.
Isolation (input-to-output):	55 dB Min.	50 dB Min.	55 dB Min.	50 dB Min.
Input Return Loss:	14 dB Min.		14 dB Min.	
Output Return Loss:	14 dB Min.		14 dB Min.	
Power Requirements:	100-240 VAC Autoranging, 50/60 Hz			
Power Consumption:	110 W typical			
Local Control:	Front panel 2.2" display and rotary knob			
Remote Control:	SNMP, TELNET, TCP/IP, Web Browser Interface Via Ethernet Remote Panel			

¹Specifications valid at unity gain (Input gain = 0 dB , Output gain = 0 dB)

*Specifications may vary with connector type. See individual specification sheet for specific performance data.

XTREME 32

32 Port Fan-Out Bi-Directional RF Matrix Switch



XTREME 32

General Description:

The **XTREME 32** DOCSIS 3.1 compatible matrix switch is a full fan-out (distributive) non-blocking signal management solution that routes an input to any or all outputs. The design features an industry exclusive architecture that supports both symmetric and asymmetric configurations of 32 combined inputs and outputs in a compact 1 RU chassis. Hot-swappable redundant power supplies, I/O Modules, and a field replaceable cooling fan provide maximum reliability.

Features & Benefits:

- 5-1800 MHz operating range
- Bidirectional configuration ideal for DOCSIS 3.1 testing
- Redundant hot-swappable power supplies
- Option for fiber optic inputs
- Hot-swappable input and output adapters
- Dual gigabit ethernet ports
- Field replaceable cooling fan

Specifications: ^{*1}	XTREME 32		
Configurations:	16x16 (Standard)		
RF Connectors:	F-Type, BNC 75 Ω or 50 Ω, SMA, Mixed or Optical Input Receivers SC/APC or LC/APC		
Impedance:	75 Ω		
Operating Frequency:	5-54 MHz	54-1218 MHz	1218-1800 MHz
Frequency Response:	+/- 4 dB	+/- 2.5 dB	+/- 2 dB
Any 6 MHz Flatness:	+/- 0.5 dB	+/- 0.5 dB	+/- 0.5 dB
Input P1dB:	30 dBm Min.		
Insertion Loss:	26	27	30
OIP3:	40 dBm Min.		
Input Return Loss:	7 dB Min. >10 dB Typical		
Output Return Loss:	7 dB Min. >10 dB Typical		
Isolation (input-to-input):	60 dB		
Isolation (output-to-output):	60 dB		
Isolation (input-to-output):	50 dB		
Local Control:	Front Panel 2.2" LCD Display with Rotary Switch Joystick		
Remote Control:	Dual 10/100/1000 Base Tx Ethernet Ports, SNMP, V2c, v3 TCp/ IP, Quintech 2.15 Protocol (Port 9100) Web server: TELNET		
Power Requirements:	100-240 VAC Autoranging, 50/60 Hz 5A Max.		
Power Consumption:	55W Typical		
Size:	1 RU: 1.75"H x 19"W x 18.5 D"		

*Specifications may vary with connector type. See individual specification sheet for specific performance data.

¹Specifications valid at unity gain (Input gain = 0 dB , Output gain = 0 dB)

XTREME RP1

Modular 1RU Chassis w/LNB Power Insertion and Redundancy Switch Cards



General Description:

The RP1 1RU modular chassis provides centralized power control and signal redundancy options. Hot-Swappable redundant power supplies, I/O Modules, and a field replaceable cooling fan provide maximum reliability. Eight card slots provide combinations of up to 16 Bias-T DC Power Inserters, eight 2x1 RF sensing and LNB power redundancy switch with Q-SENSE®, or 16 quick disconnect switchable DC power outputs. Remote control is available via web browser GUI, SNMP, or Quitech API protocol over TCP/IP.

Features & Benefits:

- 700-3000 MHz operating range
- Eight hot-swappable card slots with flexible configurations
- LNB status monitoring
- 10 MHz reference distribution to all slots
- Redundant hot swappable power supplies
- Field replaceable cooling fan

Dual LNB Bias-T Card Specifications:			
Type:	Dual		
Each Port:	Selectable 0/13/18 VDC, 22 kHz Tone 400 mA nominal (550 mA peak inrush), 750 mA (2 pin) Short Circuit Protection with Automatic Reset		
Status	Under Current (<50 mA), Short, and Normal		
Operating Frequency (MHz):	950-2150 MHz	950-2500 MHz	700-3000 MHz
Insertion Loss (Max):	1 dB	1 dB	1.5 dB
Return Loss (Min):	14 dB	12 dB	10 dB
Isolation (Min):	65 dB		
10 MHz Input Power Level (Max):	0 dBm		
RF Connectors:	F(f), BNC(f) 75 Ω or 50 Ω, SMA		

2x1 Redundancy Switch Card Specifications:			
Type:	2x1 w/RF Sensing		
Operating Frequency (MHz):	950-2150 MHz	950-2500 MHz	700-3000 MHz
Insertion Loss:	3 +/-0.5 dB	3 +/-1 dB	3.5 +/-1 dB
Return Loss (Min):	14 dB	13 dB	10 dB
Isolation (Min):	50 dB	50 dB	45 dB
RF Sensing Range:	-50 to 0 dBm		
Max Input Power:	24 dBm		
RF Connectors:	F(f), BNC(f) 75 Ω or 50 Ω, SMA		

Chassis Specifications:	
Power Requirements:	100-240 V~, 50/60 Hz
Power Consumption:	10 W Standby, 200 W Fully Loaded
Local Control:	2.2" LCD Display with Rotary Control Knob
Computer Control:	TCP/IP, Web Browser Interface, or SNMP
Size:	1 RU (1.75" H x 19" W x 18.5" D)
Weight:	12 lbs. Gross (boxed), 9 lbs. net

*Specifications may vary with connector type. See individual specification sheet for specific performance data.

RFM

RF Routing Switches



RFM

General Description:

The **RFM** is a routing switch that transparently passes RF signals. Quintech's proprietary design provides lossless switching while minimizing noise figure through the switch. It's compact design fits 16x1 in a 1 RU chassis and the switches can be cascaded to expand to 256x1. The **RFM** is used for centralized test and measurement applications and monitoring large numbers of RF signals.

Features & Benefits:

- 5-1800 MHz continuous frequency range covering all DOCSIS 3.1 to 1200 MHz and to future 1800 MHz frequencies
- L-band 950-2150 MHz frequency range
- Unity gain switching with low noise figure
- Pay as you grow, expandable in the field to 256x1
- Remote control over TCP/IP via open source API
- Web browser interface for easy setup and configuration

Applications:

- Remote testing of CATV headends and monitoring of upstream and downstream paths
- Automate testing of multiple devices under test to shared analyzer

Specifications*	RFM		
Configuration:	16x1 (Up to 256x1 with Additional Modules)		
RF Connector:	F-Type	F-Type, SMA	F-Type, SMA
Impedance:	75 Ω	50 Ω, 75 Ω	50 Ω, 75 Ω
Operating Frequency:	5-1800 MHz	950-2500 MHz	5-2500 MHz
P1dB:	+4 dBm	+5 dBm	+4 dBm
Noise Figure:	< 13 dB	<14 dB	<16 dB
OIP3:	15 dBm		
Insertion Loss:	0 dB @±1.5 dB	0 dB @±1.5 dB	0 dB @±3 dB
Input Return Loss:	13 dB	13 dB	13 dB
Output Return Loss:	14 dB	14 dB	13 dB
Isolation:	50 dB	50 dB	45 dB
Remote Control:	Ethernet Port: TCP/IP, Web Browser Interface or SNMP		
Control Module Connectors:	RJ45, XR Bus		
Expansion Module Connectors:	XR Bus		
Power Requirements:	100-240 VAC, 50/60 Hz		
Power Consumption:	9 W		
Size:	1RU: 1.75" H x 19" W x 18.5" D		

*Specifications may vary with connector type. See individual specification sheet for specific performance data.

NEXUS Wi-5G

6 GHz RF Test Matrix



NEXUS Wi-5G

General Description:

The **NEXUS Wi-5G** is a wideband 600 MHz to 6 GHz bi-directional RF attenuator matrix test system which enables automated testing of 2x2 to 8x8 MIMO connections. 64 sets of integrated fixed attenuators and 0 to 60 dB programmable attenuators provide up to 90 dB of total attenuation per connection. The **NEXUS Wi-5G** can connect any input port to one or all output ports and any output port to one or all input ports using integrated wideband splitters and combiners. Unused connections can be turned off using internally terminated 100 dB isolation switches. The **NEXUS Wi-5G** enables interoperability, coexistence and testing of current and emerging standards. The matrix is used for roaming, handover, beam forming, wireless mesh network test and validation of network equipment. Its frequency range covers 4G/LTE 5G Wireless and WiFi 6. Circuit-switched fallback testing can be conducted in a controlled environment isolated from commercial signals, emulation of mobility scenarios, interband carrier aggregation and WiFi interference tests are easily configured. Regression testing can be completed in reduced time enhancing laboratory ROI.

The **NEXUS Wi-5G** used in conjunction with Quintech's proprietary **Q-LAAMP**[®] software management platform provides a ready-to-use test system with an intuitive GUI and user configurable RF fading applications.

Features & Benefits:

- 600 MHz to 6 GHz continuous frequency range covering all major wireless and technologies
- 64 Total 0 to 60 dB programmable attenuators in 0.5 dB steps
- High power handling up to 30 dBm
- Integrated splitters and combiners support 2x2 up to 8x8 MIMO connection testing

Specifications:*	NEXUS Wi-5G
Configuration:	4x8, 8x8
RF Connectors:	N-type, SMA, QMA, TNC, 4.3-10
Impedance:	50 Ω
Operating Frequency:	600-6000 MHz
Matrix Type:	Passive Bi-Directional, Non-Blocking, Full Fan-In/Fan-Out
Switching Technology:	Solid State
IIP3:	>60 dBm
P1dB:	>36 dBm
Fixed Attenuation:	35 dB @ 6 GHz
Variable Attenuation:	0 to 60 dB Attenuation in 0.5 dB Steps
Isolation Port A to Port A:	100 dB Single Connection, 45 dB Multiple Connections
Isolation Port B to Port B:	80 dB Single Connection, 45 dB Multiple Connections
Isolation Port A to Port B:	100 dB
On/ Off Isolation: ¹	100 dB
Return Loss:	13 dB Min.
No Damage Signal Level:	+36 dBm Max.
Power Requirements:	100-240 VAC Autoranging, 50/60 Hz
Power Consumption:	20 W
Remote Control:	Ethernet, TELNET, SNMP, or TCP/IP Via Customer Supplied Control System, XR Bus for Expansion
Software:	Fast Ethernet API Protocol, Embedded Web Server and API Protocol, Q-LAAMP Option
Size:	3 RU 5.25" H x 19" W x 25.25" D
Weight:	40 lbs. Gross (Boxed), 30 lbs. Net

¹70 dB Min. normalized to insertion loss of path

*All product designs and specifications subject to change without notice. See individual specification sheet for specific performance data.

NEXUS-4

6 GHz Bi-Directional RF Attenuator Matrix Switch



NEXUS-4



General Description:

The **NEXUS-4** is a bi-directional fully non-blocking 32x32 RF matrix switching system that can route any input ports to any output ports in a 6 RU chassis. With the frequency range of 400 MHz to 6 GHz and the capability of expanding to 64x64, it enables large scale wireless testing that involves many MIMO base stations and devices. The built-in programmable attenuators and efficient automation interface provide ease-of-use testing of signal fade and emulation of mobility scenarios. It can dramatically increase lab efficiency by eliminating manual patch panel and cabling as it can be remotely reconfigured for different test setups consistently in seconds. The utilization of **NEXUS-4** RF matrices will expand your testing capabilities, improve ROI of lab instruments, and reduce time to market.

Features & Benefits:

- 400 to 6000 MHz frequency range covering all major wireless technologies
- Support 32x32 RF ports in 6 RU with modular design expandable to 64x64
- Solid state switching and attenuation for consistent, repeatable and glitchless performance; reconfigure any test setup in seconds
- Fully non-blocking splitting and combining that supports MIMO testing
- Emulate free space incremental path loss of 0 to 60 dB in 0.5 dB steps
- High power handling of up to 30 dBm (1w)
- Management software **Q-LAAMP** enables resource and time allocation for high lab efficiency

Specifications:*	NEXUS-4		
Configuration:	Up to 32 Port A/32 Port B in a Single 6 RU Chassis		
RF Connectors:	N-type, SMA, QMA, TNC, 4.3-10		
Impedance:	50 Ω		
Operating Frequency:	400-700 MHz	700-4000 MHz	4000-6000 MHz
Matrix Type:	Passive Bi-directional, Fully Non-blocking		
Switching Technology:	Solid State		
OIP3:	60 dBm Min.		
P1dB:	40 dBm Min.		
Fixed Attenuation:¹	37 dB Typical	45 dB Max.	46 dB Typical
Variable Attenuation (at Each Cross Point):	0 to 60 dB Attenuation in 0.5 dB Steps		
Isolation Port A to Port A:	100 dB Single Connection, 50 dB Multiple Connections		
Isolation Port B to Port B:	80 dB Single Connection, 50 dB Multiple Connections		
Isolation Port A to Port B:	100 dB		
On/ Off Isolation:	70 dB Min.	70 dB Min.	65 dB Min.
Return Loss:	10 dB	14 dB	10 dB
No Damage Signal Level:	+40 dBm Max.		
Power Requirements:	100-240 VAC Autoranging, 50/60 Hz		
Power Consumption:	63 W		
Local Control:	Front Panel 2.2" LCD Display with Rotary Switch Joystick		
Remote Control:	Ethernet, TELNET, SNMP, or TCP/IP Via Customer Supplied Control System, XR Bus for Expansion		
Software:	Embedded Web Server and API Protocol, Fast Ethernet Option, Q-LAAMP Option		
Size:	6 RU: 10.5" H x 19" W x 25" D		
Weight:	117 lbs in 32x32 Configuration		
Certifications:	FCC Part 15, CE, NRTL, TUV		

*All product designs and specifications subject to change without notice. See individual specification sheet for specific performance data.

NEXUS-M

6 GHz Bi-Directional RF Mesh Attenuator Matrix



NEXUS Wi-5G



NEXUS-4

General Description:

The **NEXUS-M** is a bi-directional 32 port mesh attenuator matrix where any port can connect to any or all remaining ports. With wideband frequency range spanning 400 MHz to 6 GHz, the matrix can be used for automating UHF, LTE, Bluetooth, WiFi, CAT-M, NB-IoT, and GPS component and software application tests. Each connection has an independently controlled variable attenuator, allowing power levels to be controlled between nodes. With millisecond switching speeds, software and firmware regression tests can be performed over many network configurations in a much shorter time compared to manual configuration of a patch panel. Easily configure string and mesh constellation networks for beam hopping latency measurements and network resiliency when adding or dropping nodes in software defined networks. The utilization of **NEXUS-M** RF mesh matrices will help reduce time to market of new hardware and software, and improve firmware compliance tests.

Features & Benefits:

- 400-6000 MHz frequency range covering all major wireless technologies
- Available in 8, 16 or 32 port systems
- Solid state switching and attenuation for consistent and repeatable performance
- Emulate over-the-air incremental path loss
- **Q-LAAMP** management software enables resource and time allocation for lab operation efficiency

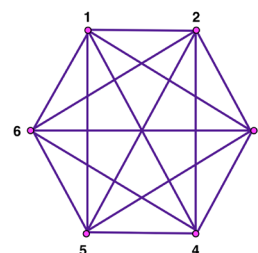
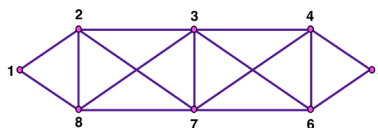
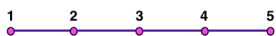

Specifications:*	NEXUS-M
Configuration:	8, 16, 32 Port Systems
RF Connectors:	N(f), SMA(f)
Impedance:	50 Ω
Operating Frequency:	400-6000 MHz
Matrix Type:	Passive Bi-directional
Switching Technology:	Solid State
P1dB:	43 dBm
Fixed Attenuation (Max):	400-700 MHz: 40 dB, 700-4000 MHz: 45 dB, 4000-6000 MHz: 50 dB
Variable Attenuation:	0 to 60 dB in 0.5 dB Steps (25 dB Dynamic Range Between Connected Ports)
On/Off Isolation:	70 dB Normalized to 0 dB Attenuation State
Return Loss:	400-700 MHz: 10 dB, 700-4000 MHz: 14 dB, 4000-6000 GHz: 10 dB
No Damage Signal Level:	+43 dBm
Local Control:	Front Panel 2.2" LCD Display with Rotary Switch Joystick
Remote Control:	Ethernet, TCP/IP Via Customer Supplied Control System
Software:	API Protocol, Q-LAAMP Embedded Web GUI
Power Requirements:	100-240 VAC, 50/60 Hz
Certifications:	FCC Part 15, CE, NRTL, TUV

*Specifications may vary with connector type. See individual specification sheet for specific performance data.

NEXUS-R

High Power Bi-Directional RF Blocking Matrix



NEXUS-R

General Description:

The **NEXUS-R** is a passive bi-directional blocking matrix switch that can relay 32 A ports to 32 B ports. It is designed to handle high power up to 50 W for direct connection to base stations. Based on latching relay switching technology, it retains the connections even upon power loss. Quintech's proprietary design minimizes the return signal and insertion loss through the switch while maximizing the isolation between ports. Its low loss and distortion preserves signal integrity for performance testing while the high isolation prevents crosstalk between test equipment. As a result, the **NEXUS-R** has superior RF performance and can be used in highly demanding applications such as base station beam forming testing.

Features & Benefits:

- Latching relays ensure cross points remain connected upon loss of power
- All active components, including RF matrix cards and power supply, are field replaceable
- Multiple modules can be combined to create larger matrices

Specifications:*	NEXUS-R
Operating Frequency:	DC – 2.8 GHz
Connector Type:	N-Type
Matrix Type:	Passive Bi-directional Blocking
Switching Technology:	Miniature RF Relay
Impedance:	50 Ω
Maximum Input RF Power:	50 W (47 dBm) at 2.5 GHz, 20C
Maximum Hot Switch RF Power:	10 W (40 dBm) at 2.5 GHz, 20C
Total RF Power into 32 Channels:	150 W CW, 20C
Amplitude Matched Channel-to-Channel:	±1 dB Max. @ 2.8 GHz
Isolation (Any Configuration):	90 dB Min.
Insertion Loss:	11 dB Max. @ 2.8 GHz
Return Loss:	14 dB Typ., 10 dB Min.
Switching Speed:	<30 Millisecond/Crosspoint
Switch Cycles to EOL:	>10 ⁶ (1 Million)
Power Requirements:	100-240 VAC Autoranging, 50/60 Hz
Power Consumption:	<100 W
Local Control:	Front Panel Keypad with LCD Display
Remote Control:	Ethernet Port; TELNET or TCP/IP Via Customer Supplied Control System, XR Bus for Expansion
Software:	Embedded Web Browser Interface
Size:	12 RU: 21" H x 19" W x 25.25" D Including Rear Handles
Mounting:	Handles and Rack Mounts Attached to Front or Rear of Box
Weight:	190 lbs Gross (Boxed), 107 lbs Net

*Specifications may vary with connector type. See individual specification sheet for specific performance data.

Q-LAAMP

Quintech Lab Automation and Management Package

General Description:

Quintech Electronics proprietary Laboratory Automation and Management Package, **Q-LAAMP**, provides lab managers the ability to manage and allocate resources such as base stations and RF instruments among many shared users. Using the **NEXUS** RF Matrix, this software manages resource allocation to labs and users without a patch panel and manual operations. Its web-based user interface provides easy access from any PC or tablet browser. **Q-LAAMP** also includes other intuitive features that facilitate testing, monitoring and troubleshooting.

Q-LAAMP makes lab management and resource sharing easy and significantly increases lab efficiency, reduce test time and save costs.

Features & Benefits:

- Schedule and resource management
- Enables multiple users to share the same lab environment
- Shared resources can be independently allocated
- Secure remote control and access to **Q-LAAMP** to avoid unauthorized changes
- Color-coded port level monitoring allows quick troubleshooting
- Port labeling to avoid confusion in a multi-user changing lab environment

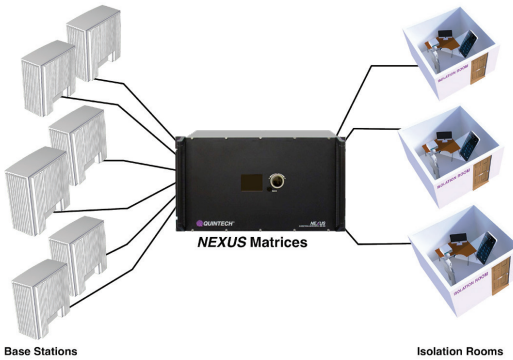

USER	PORTS	VIEW	EDIT	RENAMING	RESERVE	MIN ATTENUATION
1	1 A1	<input type="checkbox"/>	<input type="checkbox"/>	<input type="checkbox"/>	<input type="checkbox"/>	0
2	2 A2	<input checked="" type="checkbox"/>	<input type="checkbox"/>	<input type="checkbox"/>	<input type="checkbox"/>	0
3	3 A3	<input checked="" type="checkbox"/>	<input type="checkbox"/>	<input type="checkbox"/>	<input type="checkbox"/>	8.5
	4 A4	<input checked="" type="checkbox"/>	<input checked="" type="checkbox"/>	<input checked="" type="checkbox"/>	<input type="checkbox"/>	50
	5 A5	<input checked="" type="checkbox"/>	<input checked="" type="checkbox"/>	<input checked="" type="checkbox"/>	<input checked="" type="checkbox"/>	0
	6 A6	<input checked="" type="checkbox"/>	<input checked="" type="checkbox"/>	<input type="checkbox"/>	<input type="checkbox"/>	0
	7 A7	<input checked="" type="checkbox"/>	<input checked="" type="checkbox"/>	<input type="checkbox"/>	<input type="checkbox"/>	42
	8 A8	<input type="checkbox"/>	<input type="checkbox"/>	<input type="checkbox"/>	<input type="checkbox"/>	0
	9 A9	<input checked="" type="checkbox"/>	<input type="checkbox"/>	<input type="checkbox"/>	<input type="checkbox"/>	0
	10 A10	<input type="checkbox"/>	<input type="checkbox"/>	<input type="checkbox"/>	<input type="checkbox"/>	0
	11 A11	<input type="checkbox"/>	<input type="checkbox"/>	<input type="checkbox"/>	<input type="checkbox"/>	0

POWER LEVELS	PORT	LEVEL	ENABLED	OVER LEVEL	NOMINAL LEVEL	LOW LEVEL	LOCKOUT ENABLED	LOCKOUT LEVEL
	A1		On	10	0	-10	On	-70
	A2		Off	10	0	-10	Off	-99
	A3		On	12	5	-2	Off	-60
	A4		Off	10	0	-10	Off	-99
	A5		Off	10	0	-10	Off	-99
	A6		Off	10	0	-10	Off	-99
	A7		Off	10	0	-10	Off	-99
	A8		Off	10	0	-10	Off	-99

AUTOMATIC SWEEP	ENABLED	ROUTE	STEP SIZE	START ATTN	CURRENT ATTN	END ATTN
	<input checked="" type="checkbox"/>	A1 ↔ B1	3	0	1	63
	<input checked="" type="checkbox"/>	A2 ↔ B2	1	15	0	59
	<input type="checkbox"/>	A3 ↔ B3	1	0	0	63
	<input checked="" type="checkbox"/>	A4 ↔ B4	2	10	0	58
	<input type="checkbox"/>	A5 ↔ B5	1	0	0	63
	<input type="checkbox"/>	A6 ↔ B6	1	0	0	63
	<input checked="" type="checkbox"/>	A7 ↔ B7	1	1.5	0	53.5
	<input checked="" type="checkbox"/>	A8 ↔ B8	1	0	0	63
	<input type="checkbox"/>	A9 ↔ B9	1	0	0	63
	<input type="checkbox"/>	A10 ↔ B10	1	0	0	63
	<input type="checkbox"/>	A11 ↔ B11	1	0	0	63

Q-VIEW	PORT	LEVEL
A1	63	
A2	59	
A3	63	
A4	58	
A5	63	
A6	63	
A7	53.5	
A8	63	
A9	63	
A10	63	
A11	63	
B1	63	
B2	59	
B3	63	
B4	58	
B5	63	
B6	63	
B7	53.5	
B8	63	
B9	63	
B10	63	
B11	63	
B12	63	
B13	63	
B14	63	
B15	63	
B16	63	
B17	63	
B18	63	
B19	63	
B20	63	
B21	63	
B22	63	
B23	63	
B24	63	
B25	63	
B26	63	
B27	63	
B28	63	
B29	63	
B30	63	
B31	63	
B32	63	

QS/QC Series Signal Distribution

Extended L-Band Splitters & Combiners



General Description:

The **QS/QC Series** product line builds upon the well-known and proven Quitech **LS** and **LC** products. The **QS/QC Series** brings Quitech's excellent flatness and linearity to the extended L-band frequency range and provides adjustable LNB power options to meet all of your signal distribution needs now and in the future.

QS/QC

Features & Benefits:

- 50Ω 950-4000 MHz or 75Ω 850-3000 MHz Operating Range
- Multiple configurations available in a 1RU Enclosure
- 1X4 (single, dual, quad), 1X8 (single dual), 1X16 (single, dual), 1x32 (single)
- LNB Power: 750 mA 13/18 V with 22 kHz Tone, or 24V fixed
- Passive and Active Configurations available
- Power Supply Status Monitoring
- Single and Redundant DC or AC power options

Specifications*:	850-3000 MHz			950-4000 MHz		
Available Configurations	1X2 (single, dual, quad), 1X4 (single, dual, quad), 1X8 (single or dual), 1X16 (single or dual), 1X32 (single)					
Configuration:	1x4	1x8	1x16	1x4	1x8	1x16
RF Connectors:	F-Type, BNC			SMA (f)		
Impedance:	75 Ω			50 Ω		
Operating Frequency:	850-3000 MHz			950-4000MHz		
Insertion Loss: (Passive) (Splitter)	-8 +/- 2.0 dB	-11 +/- 3.0 dB	-15 +/- 3.0 dB	-8 +/- 2.0 dB	-11 +/- 3.0 dB	-15 +/- 3.0 dB
	950-2450 MHz			950-2450 MHz		
Insertion Loss: (Active) (Combiner)	-8 +/- 1.5 dB	-11 +/- 2.0 dB	-15 +/- 2.0 dB	-8 +/- 1.5 dB	-11 +/- 2.0 dB	-15 +/- 2.0 dB
	850-3000 MHz			950-4000MHz		
	0 +/- 2.0 dB	0 +/- 2.0 dB	0 +/- 2.0 dB	0 +/- 1.5 dB	0 +/- 2.0 dB	0 +/- 2.0 dB
	950-2450 MHz			950-2450 MHz		
	0 +/- 1.0 dB	0 +/- 1.0 dB	0 +/- 1.0 dB	0 +/- 1.0 dB	0 +/- 1.0 dB	0 +/- 1.0 dB
Input P1dB:	0 dBm min			0 dBm each input		
Noise Figure:	850-3000 MHz			950-4000MHz		
	(Splitter) 10 dB Max.		(Combiner) 25 dB Max.	(Splitter) 10 dB Max.		(Combiner) 23 dB Max
	950-2450 MHz			950-2450 MHz		
	(Splitter) 8 dB Max.		(Combiner) 22 dB Max.	(Splitter) 8 dB Max.		(Combiner) 20 dB Max.
OIP3: Default Gain	10 dBm Min		10 dBm Min	10 dBm Min		10 dBm Min
Input Return Loss:	850-3000 MHz			950-4000MHz		
	12 dBm		12 dBm	12 dBm		12 dBm
	950-2450 MHz			950-2450 MHz		
	14 dBm		14 dBm	14 dBm		14 dBm
Output Return Loss:	14 dBm		14 dBm	14 dBm		14 dBm
Isolation: Port to Port (Same Divider)	18 dBm		18 dBm	18 dBm		14 dBm
Isolation: Between Dividers:	50 dBm		50 dBm	50 dBm		50 dBm
Power Requirements:						
AC Input Range*:	100-240 VAC Autoranging 50/60 Hz 5A Single and Redundant Power options available					
DC Input Range*:	12-24V DC, or -48VDC* via 2-pin quick connect Single and Redundant Power options available					
Max Input Power (No Damage)	20 dBm (30 VDC max on any port)					
LNB Power*: 10W Typical power consumption plus customer LNB Power Load	AC Input Options: Switched 24V @500mA*					
	DC INput Options: Switched LNB Power (voltage matches input)					
	13V/18V, 22Hz tone switchable @ 750mA max*					
Size:	1 RU (1.75" H x 19" W x 7" D)					
Weight:	6 lbs. gross (boxed) 3lbs. net					

* Denotes optional features **Typical refers to expected product performance that is useful in application of the product but is not covered by the product warranty
*Specifications may vary with connector type. See individual specification sheet for specific performance data.

LS 2150A Series

Active (Amplified-Zero Loss) L-Band Splitters



LS12 2150A 12-way
Active L-Band Splitter

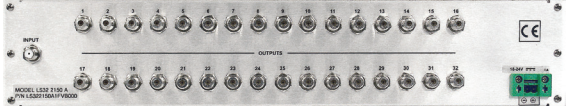

LS32 2150A 32-way
Active L-Band Splitter

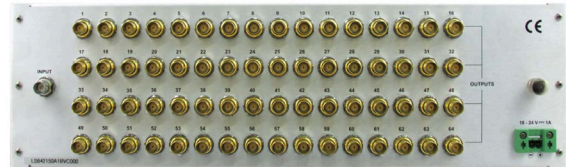

LS64 2150A 64-way
Active L-Band Splitter

General Description:

The **LS 2150** series of active L-band (950-2150 MHz) splitters permit simple splitting of RF signals to multiple destinations. Configurations available from 4 to 64 ports, including dual and quad units. A variety of powering options and features are available. Active units will power LNAs. The active splitters are DC blocked on all outputs.

Features & Benefits:

- Convenient, centralized rack mount designs improve cable management
- Microstrip design provides better performance and reliability
- Larger configurations eliminate cascading for better performance
- Active (zero loss) splitters allow for ease in RF design
- Greatly improves cable management by allowing for easy access to cable routing and easing identification of cabling
- Reduces cable connector failures by eliminating the need for frequent manual connects/disconnects

Specifications:*	LS04 2150A	LS08 2150A	LS12 2150A	LS16 2150A	LS24 2150A	LS32 2150A	LS48 2150A	LS64 2150A	
Configuration:	1x4	1x8	1x12	1x16	1x24	1x32	1x48	1x64	
RF Connectors:	F-Type, BNC 75 Ω or 50 Ω	F-Type, BNC 75 Ω or 50 Ω	F-Type, BNC 75 Ω or 50 Ω	F-Type, BNC 75 Ω or 50 Ω	F-Type, BNC 75 Ω or 50 Ω	F-Type, BNC 75 Ω or 50 Ω	F-Type, BNC 75 Ω or 50 Ω	F-Type, BNC 75 Ω or 50 Ω	
Impedance:	75 Ω, 50 Ω	75 Ω, 50 Ω	75 Ω, 50 Ω	75 Ω, 50 Ω	75 Ω, 50 Ω	75 Ω, 50 Ω	75 Ω, 50 Ω	75 Ω, 50 Ω	
Operating Frequency:	950-2150 MHz	950-2150 MHz	950-2150 MHz	950-2150 MHz	950-2150 MHz	950-2150 MHz	950-2150 MHz	950-2150 MHz	
Frequency Response:	± 1 dB	± 1 dB	± 2 dB	± 2 dB	± 2 dB	± 2 dB	± 2 dB	± 2 dB	
P1dB:	+3 dBm	0 dBm	-5 dBm	0 dBm	-10 dBm	-10 dBm	-10 dBm	-10 dBm	
Input Return Loss:	14 dB	13 dB	13 dB	14 dB	12 dB	12 dB	12 dB	12 dB	
Output Return Loss:	15 dB	16 dB	12 dB	12 dB	12 dB	12 dB	12 dB	12 dB	
Insertion Loss:	0 ± 2 dB	0 ± 2 dB	0 ± 2 dB	0 ± 2 dB	0 ± 2 dB	0 ± 2 dB	0 ± 2 dB	0 ± 2 dB	
Isolation:	18 dB	18 dB	18 dB	18 dB	18 dB	18 dB	18 dB	18 dB	
Power Requirements:	18-24 VDC Via 2-pin Quick Connect 100-240 AC 50/60 Hz	18-24 VDC Via 2-pin Quick Connect 100-240 AC 50/60 Hz	18-24 VDC Via 2-pin Quick Connect 100-240 AC 50/60 Hz	18-24 VDC Via 2-pin Quick Connect 100-240 AC 50/60 Hz	18-24 VDC Via 2-pin Quick Connect 100-240 AC 50/60 Hz	18-24 VDC Via 2-pin Quick Connect 100-240 AC 50/60 Hz	18-24 VDC Via 2-pin Quick Connect 100-240 AC 50/60 Hz	18-24 VDC Via 2-pin Quick Connect 100-240 AC 50/60 Hz	18-24 VDC Via 2-pin Quick Connect 100-240 AC 50/60 Hz
LNB Power:	18 VDC	18 VDC	18 VDC	18 VDC	18 VDC	18 VDC	18 VDC	18 VDC	
Power Consumption:	3 W	3 W	3 W	3 W	5 W	5 W	6 W	8 W	
Size:	1 RU: 1.75" H x 19" W x 6.5" D	1 RU: 1.75" H x 19" W x 6.5" D	1 RU: 1.75" H x 19" W x 6.5" D	1 RU: 1.75" H x 19" W x 6.5" D	2 RU: 3.5" H x 19" W x 14" D	2 RU: 3.5" H x 19" W x 14" D	3 RU: 5.25" H x 19" W x 20" D	3 RU: 5.25" H x 19" W x 20" D	
Weight:	4.5 lbs Gross (Boxed), 2.0 lbs Net	5 lbs Gross (Boxed), 2.7 lbs Net	5 lbs Gross (Boxed), 2.5 lbs Net	5 lbs Gross (Boxed), 2.5 lbs Net	10.5 lbs Gross (Boxed), 7 lbs Net	11 lbs Gross (Boxed), 6.2 lbs Net	15.4 lbs Gross (Boxed), 9.4 lbs Net	15.5 lbs Gross (Boxed), 9.2 lbs Net	

*Specifications may vary with connector type. See individual specification sheet for specific performance data.

LS 2150P Series Passive L-Band Splitters



LS 2150 Passive Splitter

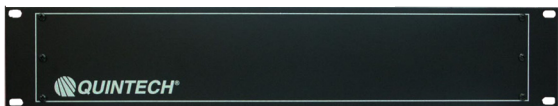

LS 2150 Passive Splitter

General Description:

The **LS 2150** series of passive L-band (950-2150 MHz) splitters permit simple splitting of RF signals to multiple destinations. Configurations available from 2 to 32 ports, including dual and quad units. A variety of features are available. The passive splitters are power and 10 MHz passing on port 1.

Features & Benefits:

- Convenient, centralized rack mount designs improve cable management
- Microstrip design provides better performance and reliability
- Larger configurations eliminate cascading for better performance
- Greatly improves cable management by allowing for easy access to cable routing and easing identification of cabling
- Reduces cable connector failures by eliminating the need for frequent manual connects/disconnects

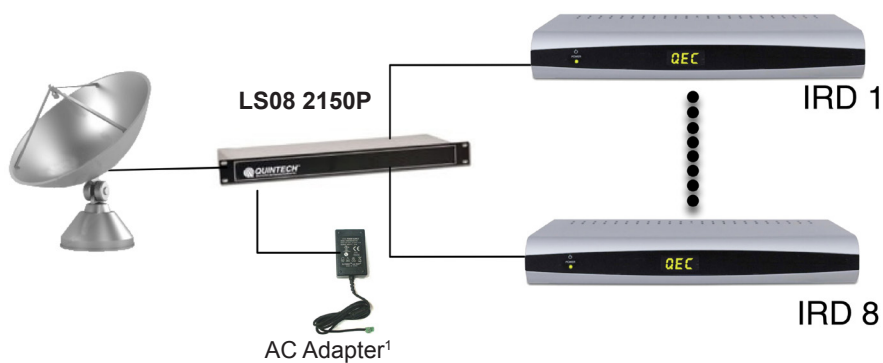

Specifications*:	LS02 2150P	LS04 2150P	LS08 2150P	LS12 2150P	LS16 2150P	LS24 2150P	LS32 2150P
Configuration:	1x2	1x4	1x8	1x12	1x16	1x24	1x32
RF Connectors:	F-Type, BNC 75 Ω or 50 Ω	F-Type, BNC 75 Ω or 50 Ω	F-Type, BNC 75 Ω or 50 Ω	F-Type, BNC 75 Ω or 50 Ω	F-Type, BNC 75 Ω or 50 Ω	F-Type, BNC 75 Ω or 50 Ω	F-Type, BNC 75 Ω or 50 Ω
Impedance:	75 Ω, 50 Ω	75 Ω, 50 Ω	75 Ω, 50 Ω	75 Ω, 50 Ω	75 Ω, 50 Ω	75 Ω, 50 Ω	75 Ω, 50 Ω
Operating Frequency:	950-2150 MHz	950-2150 MHz	950-2150 MHz	950-2150 MHz	950-2150 MHz	950-2150 MHz	950-2150 MHz
Frequency Response:	± 0.5 dB	± 1 dB	± 1 dB	± 2 dB	± 2 dB	± 2 dB	± 2 dB
Insertion Loss:	4 dB ± 0.5 dB	8 ± 1 dB	11 ± 1.5 dB	17 ± 2 dB	18 dB ± 2 dB	21 ± 2 dB	22 ± 2 dB
Input Return Loss:	11 dB	13 dB	12 dB	14 dB	14 dB	10 dB	10 dB
Output Return Loss:	15 dB	14 dB	14 dB	14 dB	14 dB	13 dB	13 dB
Isolation:	18 dB	18 dB	18 dB	20 dB	18 dB	20 dB	20 dB
Size:	1 RU: 1.75" H x 19" W x 6.5" D	1 RU: 1.75" H x 19" W x 6.5" D	1 RU: 1.75" H x 19" W x 6.5" D	1 RU: 1.75" H x 19" W x 6.5" D	1 RU: 1.75" H x 19" W x 6.5" D	2 RU: 3.5" H x 19" W x 14" D	2 RU: 3.5" H x 19" W x 14" D
Weight	3.5 lbs Gross (Boxed), 2.5 lbs Net	3.4 lbs Gross (Boxed), 2.2 lbs Net	3.7 lbs. Gross (Boxed), 2.7 lbs Net	4 lbs Gross (Boxed), 3 lbs Net	4 lbs Gross (Boxed), 3 lbs Net	9.5 lbs Gross (Boxed), 6.5 lbs Net	9.5 lbs Gross (Boxed), 6.5 lbs Net

*Specifications may vary with connector type. See individual specification sheet for specific performance data. Call for other available configurations and options.

¹Adapters sold separately

LC 2150A Series

Active (Amplified-Zero Loss) L-Band Combiners

General Description:

The LC 2150A series commercial quality active L-band combiners meet strict level, match, and loss specifications achieved through the use of Quintech's proprietary microstrip and SMT technology. These unity gain combiners operate over the satellite L-band (950-2150 MHz) frequency range and enable the combining of RF signals with repeatable performance over the entire frequency range and across all I/O ports.



LC12 2150A
12-way Active L-Band Combiner



LC24 2150A
24-way Active L-Band Combiner

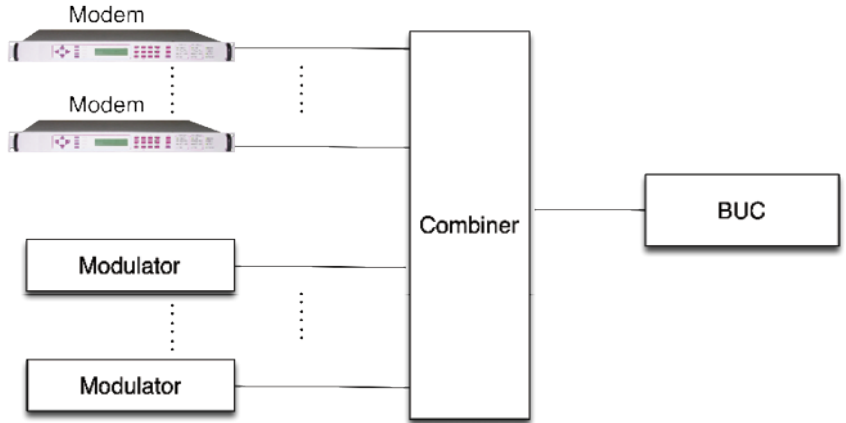

Specifications:*	LC12 2150A	LC24 2150A
Configurations:	12x1	24x1
RF Connectors:	F-Type, BNC 75 Ω or 50 Ω	F-Type, BNC 75 or 50
Impedance:	75 Ω or 50 Ω	75 Ω or 50 Ω
Operating Frequency:	950-2150 MHz	950-2150 MHz
Frequency Response:	± 2 dB	± 2.5 dB
P1dB:	-2 dBm (Each Input)	-5 dBm (Each Input)
Noise Figure:	19 dB	27 dB
Input Return Loss:	12 dB	12 dB
Output Return Loss:	12 dB	12 dB
Insertion Loss:	0 ± 2 dB	0 ± 2.5 dB
Isolation:	18 dB	18 dB
Power Requirements:	18-24 VDC Via 2-Pin Quick Connect Barrier Strip ¹	18-24 VDC Via 2-Pin Quick Connect Barrier Strip ¹
Power Consumption:	6 W	13 W
Size:	1 RU: 1.75" H x 19" W x 6.5" D	2 RU: 3.5" H x 19" W x 14" D
Weight:	5.3 lbs Gross (Boxed), 2.8 lbs Net	10 lbs Gross (Boxed), 6.5 lbs Net

*Specifications may vary with connector type. See individual specification sheet for specific performance data.

¹A/C adapter sold separately

LS 1000A Series

Active (Amplified - Zero Loss) Splitters



LS16 1000A
16-way Active Broadband Splitter



LS32 1000A
32-way Active Broadband Splitter

General Description:

The **LS** series is a commercial quality line of (5-1000 MHz) active broadband RF splitters that meet strict level, match, and loss specifications achieved through the use of Quintech's proprietary technology. Custom configurations available.

Features & Benefits:

- Convenient, centralized rack mount designs improve cable management
- Microstrip design provides better performance and reliability
- Larger configurations eliminate cascading for better performance
- Active (zero loss) splitters allow for ease in RF design
- Greatly improves cable management by allowing for easy access to cable routing and identification of cables
- Reduces cable connector failures by eliminating the need for frequent manual connects/disconnects

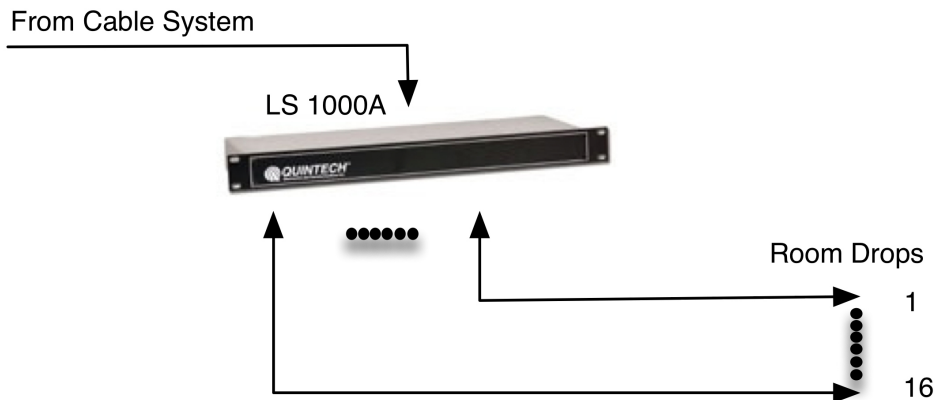

For distribution of cable feed to individual drops - downstream only

Specifications:*	LS16 1000A	LS32 1000A	LS48 1000A	LS64 1000A
Configurations:	1x16	1x32	1x48	1x64
RF Connectors:	F-Type, BNC 75 Ω	F-Type, BNC 75 Ω	F-Type, BNC 75 Ω	F-Type, BNC 75 Ω
Operating Frequency:	5-1000 MHz	5-1000 MHz	5-1000 MHz	5-1000 MHz
Frequency Response:	± 2.5 dB	± 2 dB	± 2 dB	± 2 dB
P1dB:	+6 dBm	+6 dBm	+3 dBm	+3 dBm
Input Return Loss:	13 dB	14 dB	14 dB	14 dB
Output Return Loss:	14 dB	15 dB	15 dB	15 dB
Insertion Loss:	0 + 2 dB @ 500 MHz	0 ± 2 dB @ 500 MHz	0 ± 2 dB @ 500 MHz	0 ± 2 dB @ 500 MHz
Isolation:	16 dB	18 dB	16 dB	18 dB
Power Requirements:	18-24 VDC Via 2-Pin Quick Connect 100-240 VAC, 50/60 Hz	18-24 VDC Via 2-Pin Quick Connect 100-240 VAC, 50/60 Hz	18-24 VDC Via 2-Pin Quick Connect 100-240 VAC, 50/60 Hz	18-24 VDC Via 2-Pin Quick Connect 100-240 VAC, 50/60 Hz
Power Consumption:	13 W	17 W	20 W	25 W
Size:	1 RU: 1.75" H x 19" W x 6.5" D	2 RU: 3.5" H x 19" W x 14" D	3 RU: 5.25" H x 19" W x 20" D	3 RU: 5.25" H x 19" W x 20" D

*Specifications may vary with connector type. See individual specification sheet for specific performance data.

LC 1000A Series

Active Broadband Combiners



LC64 1000A
64-way Active Broadband Combiner

General Description:

The **LC 1000A** series is a commercial quality line of (5-1000 MHz) active broadband RF combiners that meet strict level, match, and loss specifications achieved through the use of Quitech's proprietary technology. Custom configurations available.

Features & Benefits:

- Convenient, centralized rack mount designs improve cable management
- Microstrip design provides better performance and reliability
- Larger configurations eliminate cascading for better performance
- Active (zero loss) combiners allow for ease in RF design
- Greatly improves cable management by allowing for easy access to cable routing and identification of cables
- Reduces cable connector failures by eliminating the need for frequent manual connects/disconnects

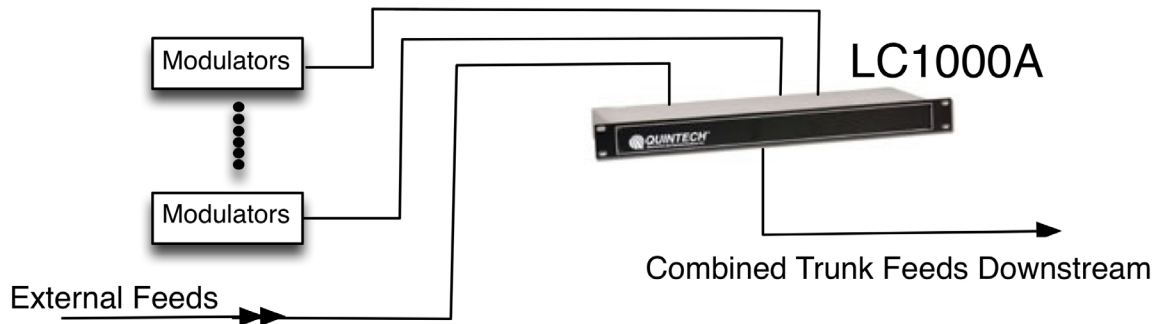

Specifications:*	LC16 1000A	LC32 1000A	LC64 1000A
Configurations:	16x1	32x1	64x1
RF Connectors:	F-Type, BNC 75Ω	F-Type, BNC 75Ω	F-Type, BNC 75Ω
Impedance:	75 Ω, 50 Ω	75 Ω, 50 Ω	75 Ω, 50 Ω
Operating Frequency:	5-1000 MHz	5-1000 MHz	5-1000 MHz
Frequency Response:	± 2.5 dB	± 2.5 dB	± 2.5 dB
P1dB:	+8 dBm Each Input	+1 dBm Each Input (Single Carrier Equivalent)	-2.0 dBm Each Input
Input Return Loss:	14 dB	12 dB	17 dB
Output Return Loss:	7 dB	12 dB	12 dB
Insertion Loss:	0 ± 2 dB @ 500 MHz	0 ± 2 dB @ 500 MHz	0 ± 2 dB @ 500 MHz
Isolation:	16 dB	16 dB	20 dB
Power Requirements:	18-24 VDC Via 2-Pin Quick Connect Barrier Strip	18-24 VDC Via 2-Pin Quick Connect Barrier Strip	18-24 VDC Via 2-Pin Quick Connect Barrier Strip
Power Consumption:	14 W	17 W	24 W
Size:	1 RU: 1.75" H x 19" W x 6.5" D	2 RU: 3.5" H x 19" W x 14" D	3 RU: 5.25" H x 19" W x 20" D

*Specifications may vary with connector type. See individual specification sheet for specific performance data. Call for additional configuration or powering. AC adapter sold separately

LSC 1000P Series

Passive Broadband Splitter/ Combiner



LSC04 1000P 4-way
Passive Broadband Splitter/Combiner



LSC32 1000P 32-way
Passive Broadband Splitter/Combiner

General Description:

The **LSC 1000P** series are commercial quality passive broadband RF splitters/combiners that meet strict level, match, and loss specifications achieved through the use of Quintech's proprietary microstrip and SMT technology. They operate over the 5-1000 MHz frequency range and enable the splitting or combining of RF signals with repeatable performance over the entire frequency range and across all I/O ports.

Specifications:*	LSC04 1000P	LSC08 1000P	LSC16 1000P	LSC32 1000P	LSC48 1000P	LSC64 1000P
Configuration:	4x1	8x1	16x1	32x1	48x1	64x1
RF Connectors:	F-Type , (BNC 75 Ω Optional)	F-Type, (BNC 75 Ω Optional)	F-Type, (BNC 75 Ω Optional)	F-Type , (BNC 75 Ω Optional)	F-Type, (BNC 75 Ω Optional)	F-Type , (BNC 75 Ω Optional)
Impedance:	75 Ω, 50 Ω	75 Ω, 50 Ω	75 Ω, 50 Ω	75 Ω, 50 Ω	75 Ω, 50 Ω	75 Ω, 50 Ω
Operating Frequency:	5-1000 MHz	5-1000 MHz	5-1000 MHz	5-1000 MHz	5-1000 MHz	5-1000 MHz
Frequency Response:	± 2 dB	± 2 dB	± 2.5 dB	± 2.5 dB	± 2 dB	± 2.5 dB
Insertion Loss:	7.5 dB ± 1 dB	11.5 dB ± 2 dB	15 dB ± 2.5 dB	18 dB ± 2.5 dB	21 dB ± 2 dB	23 dB ± 2.5 dB
Return Loss:	14 dB	12 dB	14 dB	12 dB	13 dB	12 dB
Isolation:	16 dB	16 dB	20 dB	20 dB	16 dB	20 dB
Size:	1 RU: 1.75" H x 19" W x 6.5" D	1 RU: 1.75" H x 19" W x 6.5" D	1 RU: 1.75" H x 19" W x 6.5" D	1 RU: 1.75" H x 19" W x 6.5" D	3 RU: 5.25" H x 19" W x 20" D	3 RU: 5.25" H x 19" W x 20" D
Weight:	3.5 lbs Gross (Boxed), 2.5 lbs Net	3.5 lbs Gross (Boxed), 2.5 lbs Net	4 lbs Gross (Boxed), 3 lbs Net	4.5 lbs Gross (Boxed), 3.5 lbs Net	12 lbs Gross (Boxed), 9 lbs Net	14 lbs Gross (Boxed), 9.62 lbs Net

*Specifications may vary with connector type. See individual specification sheet for specific performance data. Call for additional configuration or powering.

AMP 2150

L-Band Line Amplifier



AMP 2150



AMP 2150 Dual L-Band Line Amplifier



AMP 2150/4 Quad L-Band Line Amplifier



AMP 2150 Inline



General Description:

The **AMP 2150** series of L-band line amplifiers provide high gain as well as optional DC path continuity. These amplifiers are manufactured utilizing highly reliable surface mount technology and advanced microstrip RF circuitry and are typically deployed in satellite telecommunication networks to compensate for L-band signal paths through long coaxial cable runs. Housed in either a standard 1 RU rack mount enclosure or a rugged weatherproof extruded housing, the **AMP 2150** series amplifiers are the optimum choice for any L-band satellite communications application.

Features & Benefits:

- High (adjustable) gain over full bandwidth
- Housed in a rugged, weatherproof extruded aluminum enclosure or in a 1 RU rack mount chassis
- Passes a 10 MHz reference signal
- LNB power available

Specifications:*	AMP 2150	AMP 2150 (Dual Rack Mounted)	AMP 2150 (Quad Rack Mounted)
RF Connectors:	F-Type or BNC 75 Ω or 50 Ω	F-Type or BNC 75 Ω or 50 Ω	F-Type or BNC 75 Ω or 50 Ω
Operating Frequency:	700-2150 MHz	700-2150 MHz	700-2150 MHz
Frequency Response:	± 1 dB	± 1 dB	± 1 dB
Input P1dB:	-10 dBm	-10 dBm	-10 dBm
Noise Figure:	8 dB at +20 dB Gain	8 dB at +20 dB Gain	8 dB at +20 dB Gain
OIP3:	+4.5 dBm (with 20 dB Gain and Pin = -30 dBm)	+4.5 dBm (with 20 dB Gain and Pin = -30 dBm)	+4.5 dBm (with 20 dB Gain and Pin = -30 dBm)
Input Return Loss:	12 dB	12 dB	12 dB
Output Return Loss:	12 dB	12 dB	12 dB
Gain Range:	0 dB to +24 dB Adjustable by Internal Pot (Factory Preset to 20 dB)	0 dB to +24 dB, Adjustable From the Front Panel (Factory Preset to 20 dB)	0 dB to +24 dB, Adjustable From the Front Panel (Factory Preset to 20 dB)
10 MHz Insertion Loss:	1.5 dB ± 0.5 dB @ +20 dB Gain	1.5 dB ± 0.5 dB @ +20 dB Gain	1.5 dB ± 0.5 dB @ +20 dB Gain
Group Delay:	0.3 ns	0.3 ns	0.3 ns
Power Requirements:	+18 to +24 VDC, 190 mA	+18 to +24 VDC, 190 mA	+18 to +24 VDC, 190 mA
Power Consumption:	4.6 W	4.6 W/ AMP Module	4.6 W/ AMP Module
Power Connectors:	Via Output Connector J-hooks	Via Output Connector (AC Optional)	Via Output Connector (AC Optional)
Size:	1.25" H x 3.25" W x 5" L	1 RU: 1.75"H x 19"W x 6.5"D	1 RU: 1.75"H x 19"W x 14"D
Weight:	0.5 lbs	3.6 lbs Gross (Boxed), 2.6 lbs Net	9 lbs Gross (Boxed), 8 lbs Net
Operating Temperature:	-10° to +60° C	-10° to +60° C	-10° to +60° C

*Specifications may vary with connector type. See individual specification sheet for specific performance data. Call for custom configurations.

7800FR, 7801FR Multiframes

7801FR



7800FR



7801FR



7800FR



General Description:

The award winning Evertz 7800 family of multiframes provide flexibility in the truest form. With simultaneous processing capability of RF, Fiber, ASI, IP, 3G, HD/SD and more, these frames are designed to grow with the rapid changing needs of the facility and are available in a wide variety to defined below.

Standard features of all 7800series multiframes include dual frame genlock providing stable reference signal across the internal bus to all installed modules which minimizes the cost spent on genlock distribution, global frame status alarming to provide quick alert to operations in the event of a failure, and interchangeable modules between all frames (both processing module and companion rear plate)

Features & Benefits:

- 7800FR(-QT) houses up to 15 processing modules in 3RU
- 7801FR houses up to 4 processing modules in 1RU
- Dual frame genlock for internal reference distribution
- Front extractable modules, power supplies and fans
- AC, DC and Hybrid AC/DC power supply configurations available
- Auto-ranging power supplies operating between 100V-240V AC and 36V-60V DC
- Backwards compatible with Evertz 7800/7700 series modules
- Frame status contact closure alarm in event of failure

Specifications:*	7801FR	7800FR
Size:	Standard Rack Mountable 19" Wide 1RU	Standard Rack Mountable 19" Wide 3RU
Capacity:	Up to 4 single or 2 dual slot modules in any combination	Up to 15 single slot modules in any combination
Control:	True SNMPVistaLINK® PRO via 7801FC	True SNMP VistaLINK® PRO via 7700FC/7800FC
Air Flow Cooling:	Front to Side Exhaust Side Mounted Fans	Front to Rear Exhaust Rear Mounted Fans
Power:	Up to 125 Watts 24 watts of power per slot	Up to 360 Watts 24 watts of power per slot
Power Supply Configurations:		
Single PS	Standard with all frames	
Dual/Redundant PS	Optional	
Inlets	Separate inlets per PS	
Electrical:	100V to 240V AC, 50/60Hz Autoranging Voltage	36V to 60V DC Autoranging Voltage
Max Operating Current:	1.3A @ 100V/60Hz 0.55A @ 240V/50Hz	11A @ 48V DC
Max Power Consumption / Max Module Load:	± 2.5 dB	± 2 dB
Fuses:	+6 dBm	+6 dBm
Noise level:	13 dB	14 dB
Physical Dimensions:	14 dB	15 dB
Module Capacity:	0 + 2 dB @ 500 MHz	0 ± 2 dB @ 500 MHz
Weight:	7800FR 17.4lbs (7.9kg) empty 7800FR-48VDC 17.5lbs (7.9kg) empty	7801FR 10.0lbs (4.5kg) empty

*Specifications may vary with connector type. See individual specification sheet for specific performance data.

7807LT-2, 7807LR-2, 7708LT, 7708LR

Rack-Based Modules

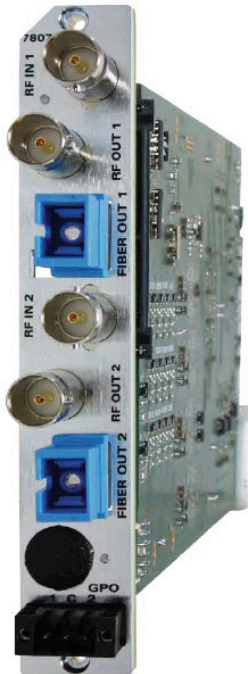

7807LT-2

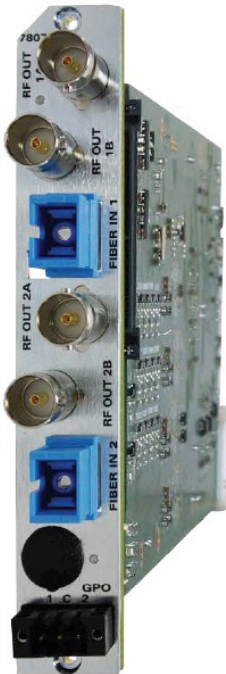

7807LR-2

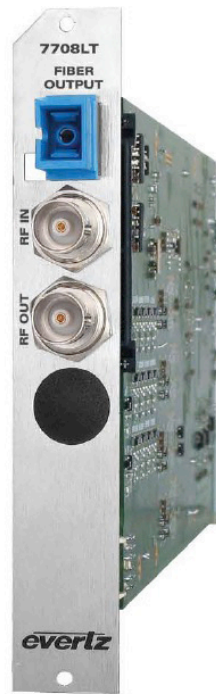

7708LT

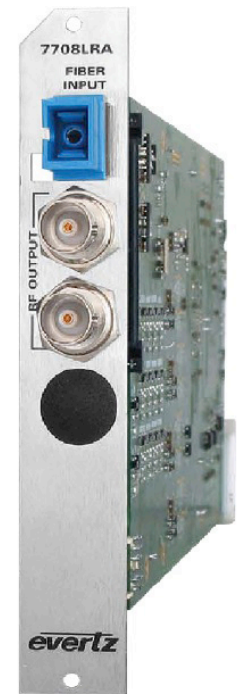

7708LR

- Single channel and dual channel Transmit and Receive modules are available in a single slot. hot-swappable form factor. Evertz RF over Fiber modules offer very flat frequency response of +/-1.SdB (worst case) resulting in linear performance and better CNR.
- Standard Tx & Rx models offer an optical budget of 16dBm for up to 45km transport. For applications with limited fiber or longer distance transport. these modules are available in coarse wavelength division multiplexing and dense wavelength division multiplexing options for transport over 100km.
- EDFA options are also available.
- Features
- Full remote monitoring & control via network monitoring service
- 13/IBV + 22kHz LNB powering
- Full power RF output per RF port for monitoring or distribution
- RF connectors available with BNC 50 or 75Ohm, F-Type, SMA
- -10 to 50 dB of manual and automatic gain control (AGC) in 1 dB step
- Fiber connectors available with SC or FC connectors and UPC or APC finish
- Dense wavelength division multiplexing options available for multiplexing up to 96 RF signals over a single fiber

The 7708LT is a fiber optic transmitter for RF signals in the extended L-Band or wider frequency range. It accepts a single RF input on coaxial cable and provides a single output for optical transmission. An RF monitor output provides a convenient means of obtaining peak satellite signal strength, or additional signal distribution.

Gain may be adjusted manually or managed automatically via AGC. With SmartMON™, incoming RF signal strength, LNB current and other data are relayed over the fiber output for monitoring through SNMP/VistaLINK® (requires SmartMON™ capable companion fiber receiver) 13/18V DC adjustable LNB power with 22kHz tone is also provided.

Features & Benefits

- Extended frequency response for extended L-Band, off-air DTV, and other signals
- Protocol independent design — transports all modulation formats
- LNB power with selectable 13/18V DC
- LNB current limit and short circuit protection
- LNB current monitoring for advance warning of LNB failure
- 22kHz tone on/off for LNB local oscillator control
- RF monitor output for signal peaking and signal distribution
- Manual gain and AGC modes
- Wide range adjustable gain in 0.5dB steps for fine tuning signal levels and optimizing CNR
- Available with 1310nm, CWDM (ITU-T G.694.2) and +11dBm high power DWDM (ITU-T G.694.1) laser options
- SmartMON™ capability provides remote status monitoring via SNMP without a separate data connection
- VistaLINK® capability is available for monitoring and control when modules are used in a 3RU 350FR, 7800FR frame and a 7700FC VistaLINK® frame controller is installed in Slot 1 of the frame
- Fiber link provides electrical isolation between antenna and facility, mitigating ground loop and lightning issues
- The 7708LT occupies one card slot and can be housed in a 1RU frame that will hold up to 3x modules, a 3RU frame that will hold up to 15x modules, a 350FR which will hold up to 7x modules or a standalone enclosure, which holds one module

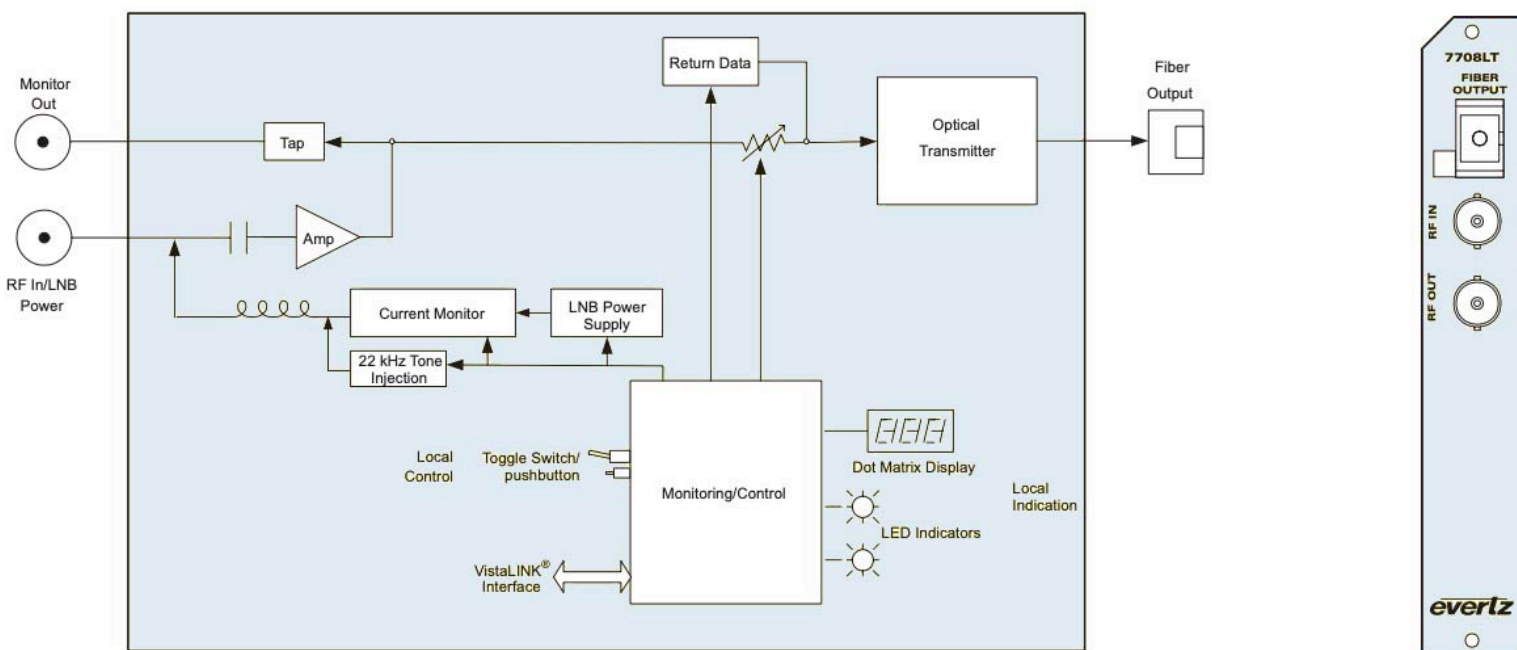

Specifications

RF Input:	
Number of Inputs:	1
Connector:	BNC per IEC 61169–8 Annex A (F-Type and SMA Optional)
Input Impedance:	75Ω (50Ω Optional)
Frequency Range:	50–3000MHz
Return Loss:	
120MHz–2.3GHz:	> 14dB
2.3–3GHz:	> 12dB
Input Power Range:	–10dBm to –60dBm
Gain Range:	0 to +30dBm in 0.5dB steps
IMD:	< –55dBc at –15dBm input and 0dB gain
Input IP3:	+10dBm
LNB Power:	
Voltage:	13V DC, 18V DC, off (selectable)
Current:	400mA
Protection:	Short Circuit, current limited
LO Control:	22kHz on/off (selectable)
RF Monitor Output:	
Number of Outputs:	1
Connector:	BNC per IEC 61169–8 Annex A (F-Type and SMA Optional)
Output Impedance:	75Ω (50Ω Optional)
Return Loss:	> 15dB

Frequency Range:	50–3000MHz
Output Level:	Within –2.0dB of input signal
Optical Output:	
Number of Outputs:	1
Connector:	Female SC/UPC, ST/UPC, FC/UPC, SC/APC, FC/APC
Operating Wavelength:	
Standard:	1310nm DFB
CWDM:	1270–1610nm
DWDM:	C-Band (ITU G.694.1 compliant)
Output Power:	
Standard 1310nm:	+2dBm
CWDM:	+2dBm
DWDM:	+11dBm

RF System Performance 7708LT+7708LRA pair:	
Frequency Response:	
950–2150MHz:	± 1.5dB
120MHz–3GHz:	± 2dB
±0.25dB on 36MHz BW to 2.3GHz	

RF System Performance 7708LT+7708LR–H pair:	
Frequency Response:	
950–2150MHz:	± 1.5dB
120MHz–2.3GHz:	± 2dB
±0.25dB on 36MHz BW	

10MHz Performance	
7708T13–10MHz+7708R–10MHz pair:	
Manual Gain Range:	–5 to +10dB
Input Power Range:	+10 to –40dBm
OIP3:	+29dB
Harmonic Rejection:	+60dB
Electrical:	
Voltage:	+12V DC
Power:	6W max excluding LNB Power
Physical (Number of Slots):	
350FR:	1
7700FR–C:	1
7800FR:	1

Compliance:	
Laser safety:	Class 1 laser product Complies with 24 CFR 1040.10 and 1040.11, IEC 60825–1 Complies with FCC Part 15, Class A EU EMC directive
EMI/RFI:	

7882IRD Series

DVBS/S/S2X MPEG-2/H.264 SD/HD Integrated Receiver Decoders

The 7882IRD Series is the basis of a professional platform for receiving, demodulating and decoding digital DVB-S/S2/S2X satellite signals. With a compact, modular form-factor the 7882IRD represents one of the highest density and most flexible solutions in the industry. The 7882IRD-S2X may be mounted in Evertz' 7800 series enclosures, providing a high-density, modular solution. Options for an innovative removable front control panel and 1RU chassis also allow the IRD to be packaged in the traditional IRD form factor, while maintaining all of the benefits of modularity.

Applications include signal reception for broadcasters, cable, DTH and IPTV providers, or any other small to large head-end operators who need to receive and utilize or re-distribute satellite content. The 7882IRD series provides ASI and IP outputs, ideal for turnaround, transcoding, monitoring or other applications where the received signal remains in the compressed domain. For baseband output, the 7882IRD2 utilizes an advanced decoder with support for both MPEG-2 and H.264/AVC, SD or HD encoded signals, optionally up to 4:2:2 10-bit.

In addition to a quad-RF input, the 7882IRD also provides inputs for IP and ASI signals, making it a future-proof, universal reception platform for signals delivered over satellite, fiber and other network media. Monitoring parameters such as EsNo ratio, RF power, BER and packet errors present a convenient solution for broadcasters and cable companies who wish to not only receive, but also remotely monitor signal quality. Also, these parameters as well as Full monitoring and control of the IRD are relayed over SNMP, for convenient remote access using Evertz own VistaLINK® PRO SNMP monitoring and control package. Additionally, low-speed data support is provided for in-band control.

For applications requiring decryption, the IRD provides a slot for installation of a customer supplied conditional access module. DVB-CI compliant conditional access modules and formats are supported.

► Features & Benefits

- Modular design, allowing flexible configurations along with easy system reconfiguration and service
- May be mounted in the 7800FR series frames in high-density applications
- May be mounted in the 7801FR and fitted with the 7801CP control panel, yielding a 1RU 7882IRD with removable front control panel and optional redundant power supplies, all of which are hot-swappable and may be serviced without any de-cabling required
- Up to two units may be mounted in the 7801FR and used with the 7801CP, providing a dual-IRD solution in 1RU
- Future-proof with upgrade paths to support future modulation and encoding technologies
- Standard support for advanced modulation schemes, including DVB-S2 with 16APSK, 32APSK and 64APSK
- Optional DVB-S2X Modulation support
- Standard support for advanced transport stream processing including service filtering and output bitrate control
- Long frames and Short frames
- CCM, VCM and ACM
- SCPC and MCPC support
- Automatic detection and configuration of modulation type, filter roll-off, symbol rate, pilot presence (on/off) and frame length
- Supports optional on-board Input auto-failover between various inputs including RF/ASI or IP inputs
- Flexible decoding of SD and HD as standard
- Support for encoding profiles from distribution to contribution grade, including H.264 in 4:2:0 8-bit and optional 4:2:2 10-bit formats "software upgradable", along with legacy MPEG-2
- Available DVB-CI slot for conditional access modules
- Available BISS and BISS-E decryption
- Flexible mid-stage access to compressed domain signals, including ASI and optional IP output along with ASI and optional IP inputs
- Straight pass through or PID filtering/remapping of compressed stream outputs
- Standard Dolby® pass through and decode of Dolby® AC3 and MPEG-2 Layer 1 audio
- Optional decoding of Dolby® E, Dolby® Plus and AAC
- Eight AES outputs
- Optional Audio Video Monitoring (AVM option) for audio mute and video freeze and black detection
- Optional SCTE 105/34 translation
- Control through web-browser or SNMP using third-party application or Evertz' own VistaLINK® SNMP control and monitoring software
- Ability to store ten preset configurations
- Event log support with exporting capabilities are supported on VLPRO and built-in Control port for direct control and management of the IRD

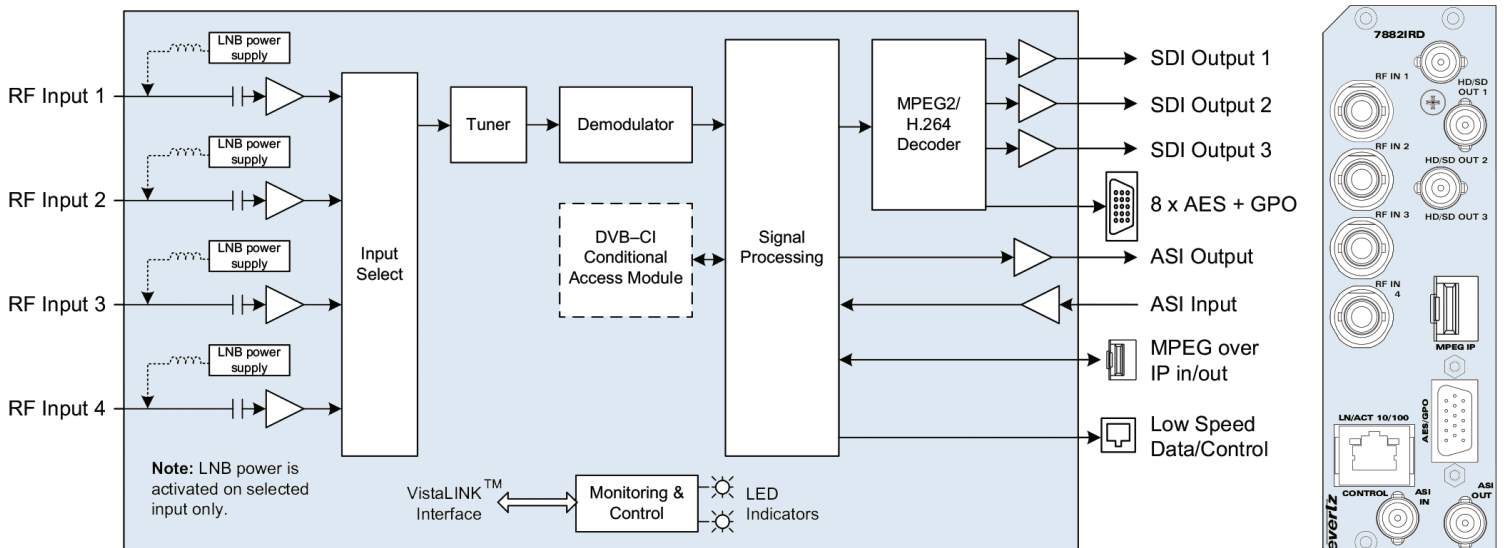

7882IRD Series

DVBS/S/S2X MPEG-2/H.264 SD/HD Integrated Receiver Decoders

► Specifications

RF Input:	FECFRAME (short) 16 200 (bits)	Compression Format:
Number: 4	DVB-S2x QPSK: 1/4, 1/3, 2/5, 1/2, 3/5, 2/3, 3/4, 4/5, 5/6, 8/9, 9/10, 11/45, 4/15, 14/45, 7/15, 8/15, 32/45	MP1L2 and Dolby® Digital AC-3 upto 3/2L
Connector: 75Ω F-Type (optional BNC connector)	DVB-S2x 8PSK: 3/5, 2/3, 3/4, 5/6, 8/9, 7/15, 8/15, 26/45, 32/45	Passthrough: PCM, Dolby® Digital, Dolby® E
Frequency: 950–2150 MHz	DVB-S2x 16APSK: 2/3, 3/4, 4/5, 5/6, 8/9, 7/15, 8/15, 26/45, 3/5, 32/45	Optional: Dolby® E decode and AAC-LC
Power: –20 to –65 dBm	DVB-S2x 32APSK-L: 2/3, 3/4, 5/6, 8/9, 7/15, 8/15, 26/45, 3/5, 32/45	Ancillary Data:
Voltage: 13/18V DC, off (selectable)		Embedding of: Audio passthrough Closed caption/Teletext SCTE35 to 104 (+SCTE104 option)
Max Current: 400mA		AFD/WSS
Protection: Short circuit, overload		Time code
Local Oscillator Control: 22kHz on/off (selectable); 1000–35000MHz to be used for C-Band & Ku-Band	ASI Input:	
Input Return Loss: 15dB Min.	Number: 1	
Noise Figure: 9dB Max.	Type: ASI per DVB TR101–891	
AFC Tuning Range: ±67MHz using search range	Connector: 75Ω BNC	
IF Filter Bandwidth: Adjusted from 6MHz to 50MHz in 1MHz steps		
	ASI Output:	
	Number: 1	
	Type: ASI per DVB TR101–891	
	Connector: 75Ω BNC	
		High Quality Down Convert (+HDC option):
		Down Conversion: SMPTE ST 292 to ST 259
		Aspect Ratio: Fixed Scalar or follow AFD
		<i>Note: +HDC feature is not supported when decoding 3G video</i>
Modulation Support:	MPEG over IP Input/Output (+IP Option):	Low Speed Data:
Symbol Rate: Up to:	Number: 1	Number: 1
QPSK, 8PSK, 16APSK:	Type: SMPTE ST 2022–1, –2	Type: De-encapsulation from control data PID
64 Msps	Connector: 1GbE Data port using SFP (SFP ordered separately)	Connector: RJ-45, 10/100/1000
32APSK: 51 Msps		
64APSK: 43 Msps		
		Frame Sync (+FSE Option):
		• Sync 1080i/59.94, 1080i/50, 720p/59.94, 720p/50, 525i/59.94, 625i/50
		• Video Delay between 3x lines and 1x frame + 3x lines
		• Programmable output phase with respect to reference input
		• Reference input via common 7800FR/7801FR frame reference connector
		Control:
		• SNMP over Ethernet via frame controller
		• Web browser
		• Low speed control data over Ethernet output derived from data PID
		• 4x GPO following commercial trigger
		Electrical:
		Power: <46 Watts
		Voltage: 12V DC
		Temperature: 0–50°C
		Physical:
		Number of Slots: 2
Coding Rates:	Conditional Access Support:	
FECFRAME (normal) 64 800 (bits)	One DVB-CI slot	
DVB-S QPSK: 1/2, 2/3, 3/4, 5/6, 7/8		
DVB-S2 QPSK: 1/4, 1/3, 2/5, 1/2, 3/5, 2/3, 3/4, 4/5, 5/6, 8/9, 9/10	Baseband Video Outputs:	
DVB-S2 8PSK: 3/5, 2/3, 3/4, 5/6, 8/9, 9/10	Number: 3 (third BNC is configurable to be ASI or SDI output)	
DVB-S2 16APSK: 2/3, 3/4, 4/5, 5/6, 8/9, 9/10	Connector: 75Ω BNC	
DVB-S2 32APSK: 3/4, 4/5, 5/6, 8/9, 9/10	Type: SDI (SMPTE ST 259), HD-SDI (SMPTE ST 292–1), SMPTE ST 272–1994 (10-bit) 270Mb/s, 3Gb/s (SMPTE ST 424M/ST 424M-AB)	
DVB-S2x QPSK: 1/4, 1/3, 2/5, 1/2, 3/5, 2/3, 3/4, 4/5, 5/6, 8/9, 9/10, 13/45, 9/20, 11/20		
DVB-S2x 8PSK: 3/5, 2/3, 3/4, 5/6, 8/9, 9/10, 23/36, 25/36, 13/18		
DVB-S2x 8APSK-L: 5/9, 26/45		
DVB-S2x 16APSK: 2/3, 3/4, 4/5, 5/6, 8/9, 9/10 (S2-MODCODs), 26/45, 3/5, 28/45, 23/36, 25/36, 13/18, 7/9, 77/90		
DVB-S2x 16APSK-L: 5/9, 8/15, 1/2, 3/5, 2/3		
DVB-S2x 32APSK: 3/4, 4/5, 5/6, 8/9, 9/10, 32/45, 11/15, 7/9		
DVB-S2x 32APSK-L: 2/3		
DVB-S2x 64APSK: 11/15, 7/9, 4/5, 5/6		
DVB-S2x 64APSK-L: 32/45		
	<i>Note: +HDC feature is not supported when decoding 3G video</i>	
	AES Audio Outputs:	
	Number: 8 PIDS (16 channels of embedded PCM)	
	Connector: BNC breakout from DB-15	
	Type: Unbalanced AES	
	Standard: AES3 (aka AES/EBU) as an AES output standard	

Evertz 2406LR/ 2408LT

L-Band/Wideband Standalone Fiber Receiver Series



Evertz 2406LR

RX Specifications:*	Evertz 2406LR
Operating Frequency:	88 MHz - 3000 MHz
Output IMD:	< -55 dBc @ -3 dBm Output and 25 dB Gain
P1dB:	+28 dBm
RF Gain:	-6 dB to +24 dB in 2 dB Steps
Return Loss:	> 15 dB 88 MHz – 2300 MHz
Optical Connector:	FC/APC
Optical Wavelength:	1270 to 1610 nm
Max Optical Input Power:	+3 dBm
RF Connector:	F-Type, 50 Ω BNC
Power:	4.8 – 5.2V DC
Size:	5.4"L x 2.4"W x 1.2"H
Environment:	IP65

*Specifications may vary with connector type. See individual specification sheet for specific performance data.

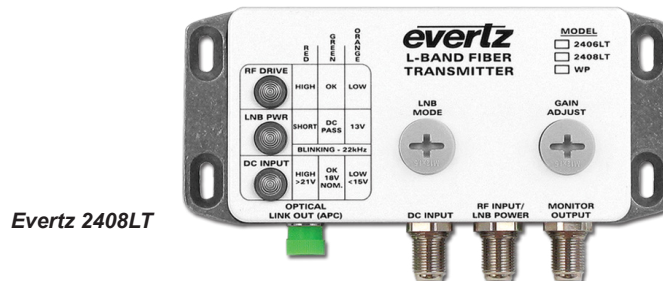

Evertz 2408LT

RX Specifications:*	Evertz 2408LT
Operating Frequency:	88 – 3000 MHz
RF Input Power:	-60 dBm to -10 dBm
Output IMD:	< -55 dBc @ -15 dB Input and Min. Gain
LNB Power:	13 V, Off and 0 Hz, 22 kHz
RF Gain:	+2 to +30 dB in 2 dB Steps
Return Loss:	88 – 500 MHz > 11 dB 500 MHz – 3000 MHz > 15 dB
Optical Connector:	FC/APC
Optical Wavelength:	1310 nm
Optical Power Output:	+2 dBm
Laser Type:	DFB
RF Connector:	F-Type, 50 Ω BNC
Power:	4.8 – 5.2V DC
Size:	5.4"L x 2.4"W x 1.2"H
Environment:	IP65

*Specifications may vary with connector type. See individual specification sheet for specific performance data.

Evertz 2400 ODU

Outdoor Integrated RF Fiber Transmission System

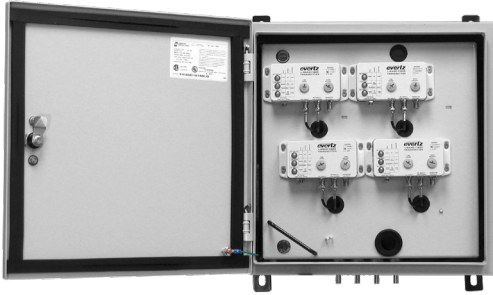

2400 ODU



General Description:

The 2400ODU-8 is a compact, weatherproof enclosure that provides a convenient, pre-integrated package for fiber transport of satellite and other signals within the extended L-Band range. The 2400ODU-8 can house up to 8x active fiber transmit (2408LT) or receive (2406LR) modules and an 8-channel power supply (2400PSUA-8).

The 2400ODU comes with mounting brackets to be conveniently mounted directly on or near the antenna structure.

This turnkey solution provides fiber transport of up to 8x RF signals over individual fibers or multiplexed over a single fiber, and power the connected LNBs.

The 2400ODU-8 also features built-in surge protectors for lightning protection and has options for integrated fiber multiplexer, 10MHz reference transport, RF protection switching, splitters, Bias-Tee and more.

Features & Benefits:

- Fiber link provides electrical isolation between antenna and facility, mitigating ground loop and lightning issues
- Weather-sealed enclosure with durable powder coat finish
- Wide operating temperature range
- Lightning protection included on RF inputs/outputs
- LNB current monitoring for advance warning of LNB failure
- Serial and Ethernet data transceivers available for remote antenna control, monitoring and other applications
- All modules are field-replaceable and hot-swappable
- SmartMON™ monitoring without a separate data connection
- Redundant power supply

Chassis Specifications:*	Evertz 2400 ODU
Slots:	8
Channels (max):	8
Power Consumption:	<1 Amp Per Input
Size:	9" D x 16" W x 16" H
Weight (chassis only):	11 lbs
Environment:	-30 to +80°C

*Specifications may vary with connector type. See individual specification sheet for specific performance data.

7780D4A-ASI

Quad ASI TDM-Demux

Features & Benefits

- Single card TDM demultiplexer for four DVB-ASI transport streams
- Adjacent outputs unaffected by loss of any DVB-ASI input feed at the 7780M4-ASI TDM Mux
- Fully hot-swappable from front of frame
- Monitor port output is user-selectable from the four ASI outputs
- Comprehensive signal and card status monitoring via four digit card edge display or remotely through SNMP and VistaLINK®
- VistaLINK® capability is available when modules are used with the 3RU 7700FR-C frame and a 7700FC VistaLINK® Frame Controller module in slot 1 of the frame
- Occupies one card slot & can be housed in a standalone frame, a 1RU frame holding up to 3 modules or a 3RU frame holding up to 15 modules

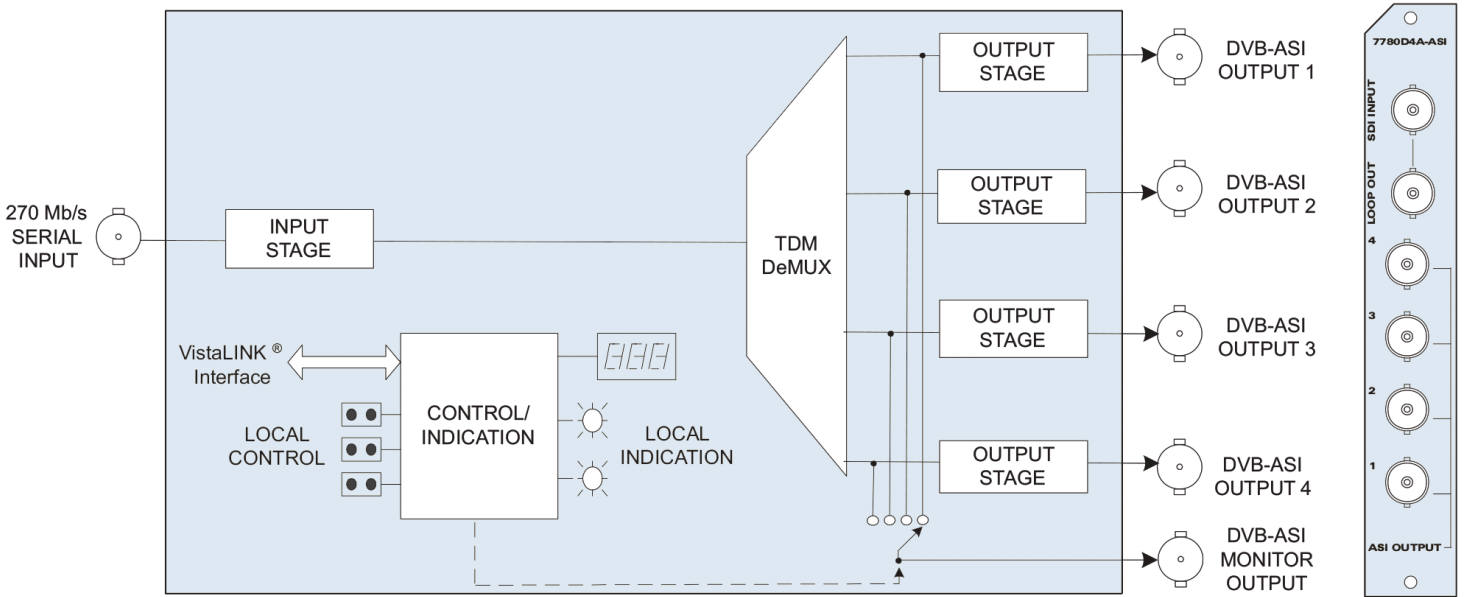

Specifications

Serial Input:		Serial ASI Outputs:		Electrical:	
Standard:	SMPTE ST 259-C compliant TDM stream as provided by companion 7780M4-ASI	Standard:	DVB-ASI: DVB TR 101 891-270	Voltage:	+12V DC
Number of inputs:	1	Number of Outputs:	4 independent DVB-ASI	Power:	10W
Connector:	BNC per IEC 61169-8 Annex A	Monitor Output:	1 output, selectable from outputs 1-4	EMI/RFI:	Complies with FCC Part 15, Class A EU EMC directive
Signal Level:	800mV nominal	Connector:	BNC per IEC 61169-8 Annex A	Physical (number of slots):	
Equalization:	Automatic to 250m @ 270Mb/s with Belden 8281 or equivalent cable	Signal Level:	800mV nominal	350FR:	1
Return Loss:	> 15dB up to 270Mb/s	DC Offset:	0V ±0.5V	7700FR-C:	1
		Rise and Fall Time:	900ps nominal		
		Overshoot:	< 10% of amplitude		
		Return Loss:	> 15dB up to 270Mb/s		
		Wide Band Jitter:	< 0.2 UI		

7780M4-ASI

Quad ASI TDM-Mux

►Features & Benefits

- Single card TDM multiplexer for four DVB-ASI transport streams
- Inputs may be MPTS or SPTS with a combined bandwidth of up to 210Mb/s
- Signal transport uninterrupted by loss of any/all DVB-ASI input feeds
- Comprehensive signal and card status monitoring via four digit card edge display or remotely through SNMP and VistaLINK®

- VistaLINK® capability is available when modules are used with the 3RU 7700FR-C frame and a 7700FC VistaLINK® Frame Controller module in slot 1 of the frame
- Fully hot-swappable from front of frame
- Output is a single 270Mb/s signal compatible with SMPTE 259M-C transport
- Monitor port output is user-selectable from the four inputs

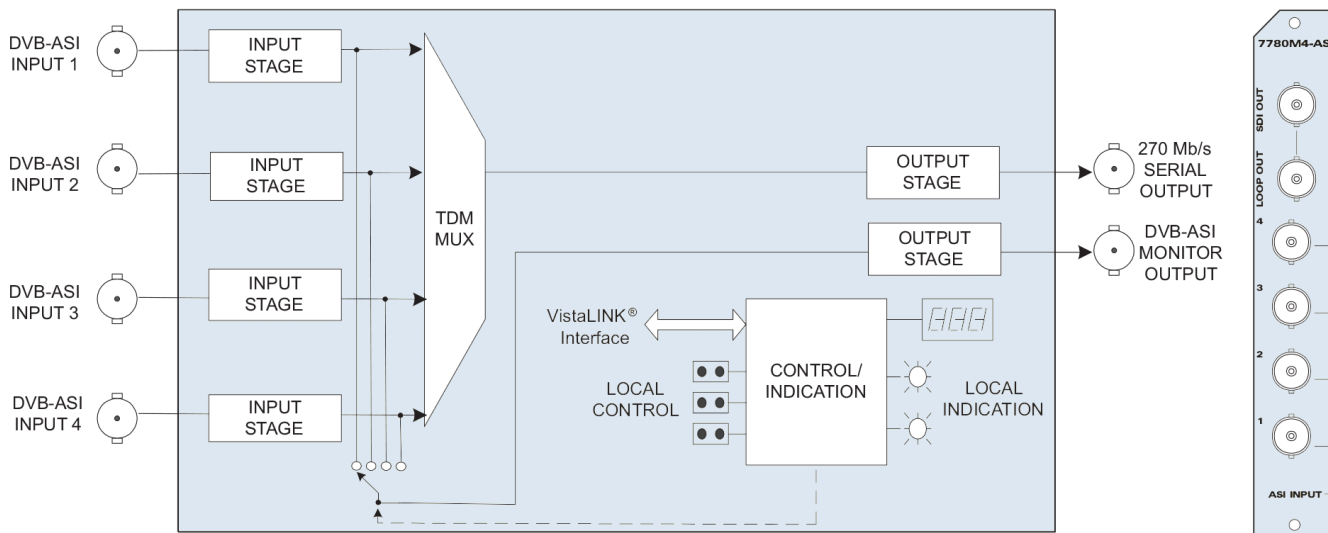

►Specifications

ASI Input:	Output:	Physical:
Standard: DVB-ASI: DVB TR 101 891-270	Standards:	350FR: 1
Number of inputs: 4 independent DVB-ASI 270Mb/s signals	Output: SMPTE 259M-C framing compatible	7700FR-C: 1
Max Input Bitrate: 210Mb/s	Monitor: DVB-ASI output	7800FR: 1
Connector: 4 BNC per IEC 61169-8 Annex A	Total Active Bitrate: 210Mb/s	Compliance:
Return Loss: > 15dB up to 270Mb/s	Number: 1 + 1 monitor	Electrical Safety: CSA Listed to UL 60065-03, IEC 60065
	Connector: BNC per IEC 61169-8 Annex A	Complies with CE Low voltage Directive
	Signal Level: 800mV nominal	EMI/RFI: Complies with FCC Part 15, Class A
	DC Offset: 0V ±0.5V	EU EMC Directive
	Rise and Fall Time: 900ps nominal	
	Overshoot: < 10% of amplitude	
	Return Loss: > 15dB up to 270Mb/s	
	Wide Band Jitter: < 0.2 UI	
	Electrical:	
	Voltage: +12V DC	
	Power: 10W	

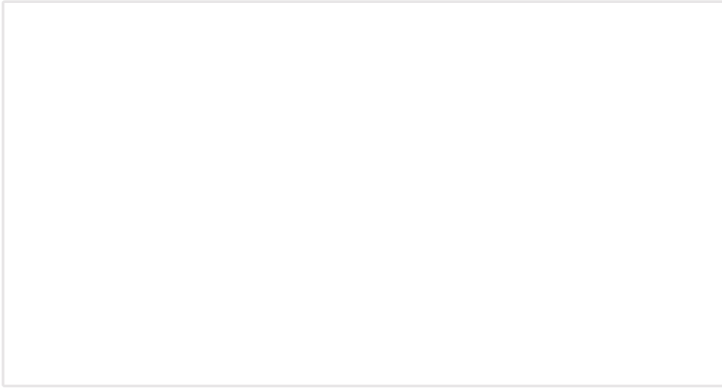

Quintech Electronics & Communications, Inc.
250 Airport Road
Indiana, PA 15701 USA



Toll Free: 1-800-839-3658
Telephone: 1-724-349-1412
Fax: 1-724-349-1421
Email: info@quintechelectronics.com

www.quintechelectronics.com

Made in the USA